

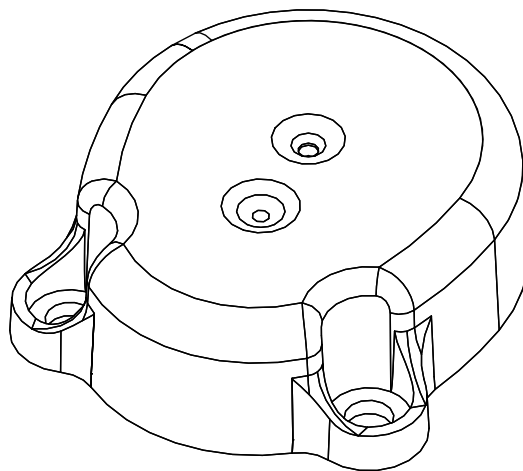

Ultra compact sealed recording device

## User's manual



●oooo by FiveCo

En Budron H11  
CH-1052 Le Mont-sur-Lausanne  
Tél : +41 21 632 60 10  
[info@theye.ch](mailto:info@theye.ch) / <http://www.theye.ch>



THEye

Compact Bluetooth® logger for secure temperature and humidity recording.



THEye Controller

Smartphone application for monitoring THEye products.



THEye Cloud

Swiss service for data storage and access control (security) of THEye products.



THEye Dashboard

User-friendly web application that provides access to THEye Cloud data and features.



THEye Gateway

Download data automatically from nearby THEye to transmit their data to the server.

# Table of content

<b>1.</b>	<b>Quick start guides</b> .....	<b>5</b>
1.1	Install THEye Controller and connect to your THEye	6
1.2	Link your THEye with a THEye Cloud account	7
1.3	Secure your data and view it on THEye Dashboard	8
<b>2.</b>	<b>Technology</b> .....	<b>9</b>
2.1	Overview of the technology	9
2.2	Use cases	9
2.3	Target audience	9
<b>3.</b>	<b>THEye product range</b> .....	<b>10</b>
<b>4.</b>	<b>THEye TH-2 and THEye TH-2 ISO</b> .....	<b>11</b>
4.1	Characteristics	11
4.2	Time management	14
4.3	Bluetooth® communication	15
4.4	Labels	16
4.5	Packaging	16
4.6	Installation	17
<b>5.</b>	<b>THEye Controller</b> .....	<b>20</b>
5.1	Downloading and installation	20
5.2	Symbols	21
5.3	Application pages	24
5.4	Features	30
<b>6.</b>	<b>THEye Cloud</b> .....	<b>34</b>
6.1	Encryption, data integrity	34
6.2	THEye is secured by the THEye Cloud account	34
6.3	Subscriptions and prices	36
<b>7.</b>	<b>THEye Dashboard</b> .....	<b>37</b>
7.1	Record review page	37
<b>8.</b>	<b>THEye Gateway</b> .....	<b>41</b>
8.1	Characteristics	41
8.2	Installation	41
8.3	How it works	42
8.4	Configuration	43
8.5	Firmware update	49
8.6	Modbus TCP	49
<b>9.</b>	<b>Standards and safety</b> .....	<b>52</b>
9.1	Safety	52

9.2	Materials and conception	52
9.3	IP68	53
9.4	Storage	53
9.5	Working pressure	53
9.6	EC Declaration of conformity	54
9.7	EN12830	55

## 1. Quick start guides

Thank you for choosing a THEye product. For a quick installation, the following quick start guides are available:

- Install THEye Controller and connect to your THEye
- Link your THEye with a THEye Cloud account
- Secure your data and view it on THEye Dashboard



*More advanced operations such as setting up and starting a new record or setting the THEye protection level are detailed later in this manual.*

## 1.1 Install THEye Controller and connect to your THEye

### 1 Install the THEye Controller application

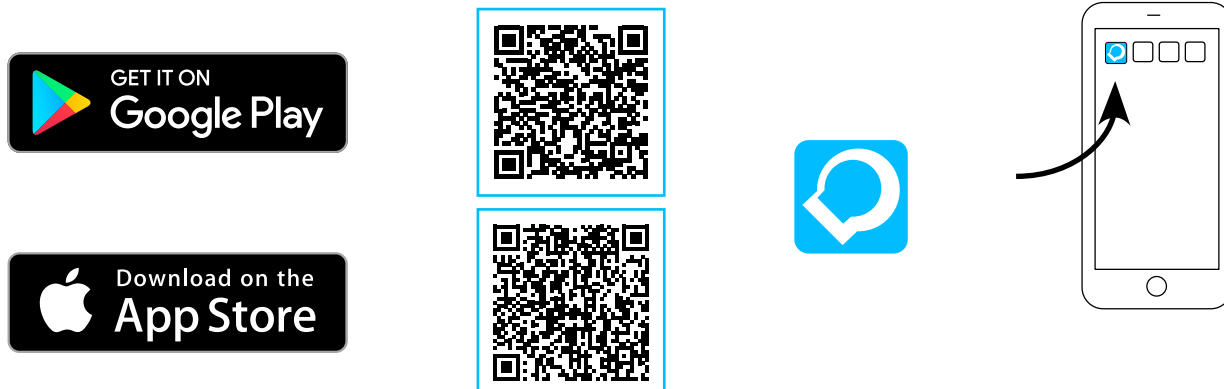

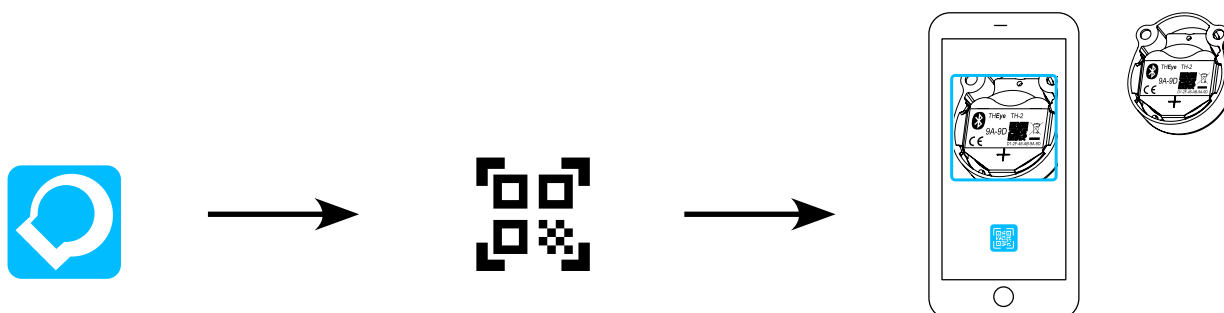

### 2 Launch the application and connect your THEye module by scanning the QR code on the module



 *In order to activate the Bluetooth® features, the application asks for permissions when it first starts. It is necessary to accept all the authorizations for the application to work properly.*

### 3 Congratulations! You have access to your THEye! Take advantage of its many features

-  Access the history of the measurements recorded on the THEye.
-  Locate your THEye by flashing it.
-  Share the history of measurements.

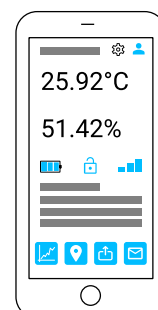

... and many others.

## 1.2 Link your THEye with a THEye Cloud account

- 1 Create a THEye Cloud account by going to THEye Dashboard

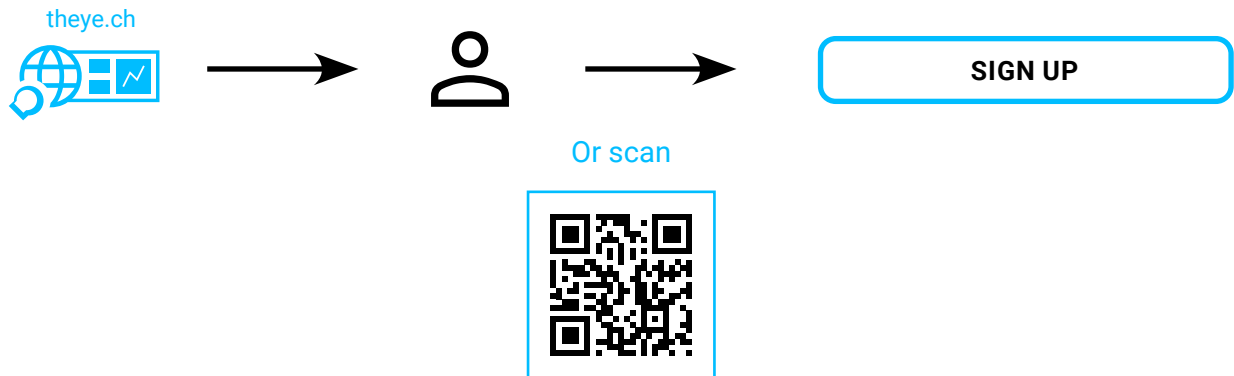

**i** THEye Cloud works on a free subscription basis offering the basic features of the service. For advanced use, various fee plans allow access to the full potential of the THEye ecosystem (see point 6.3)

- 2 Use your credentials to authenticate in the THEye Controller app.

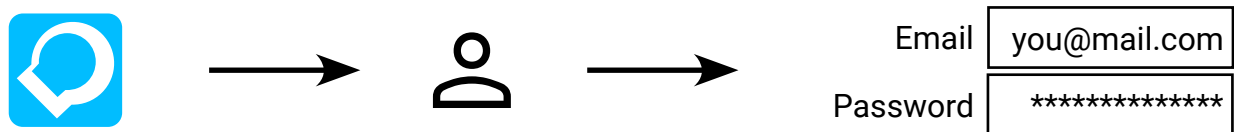

- 3 Log in to your THEye from the THEye Controller app and associate it with your THEye Cloud account!

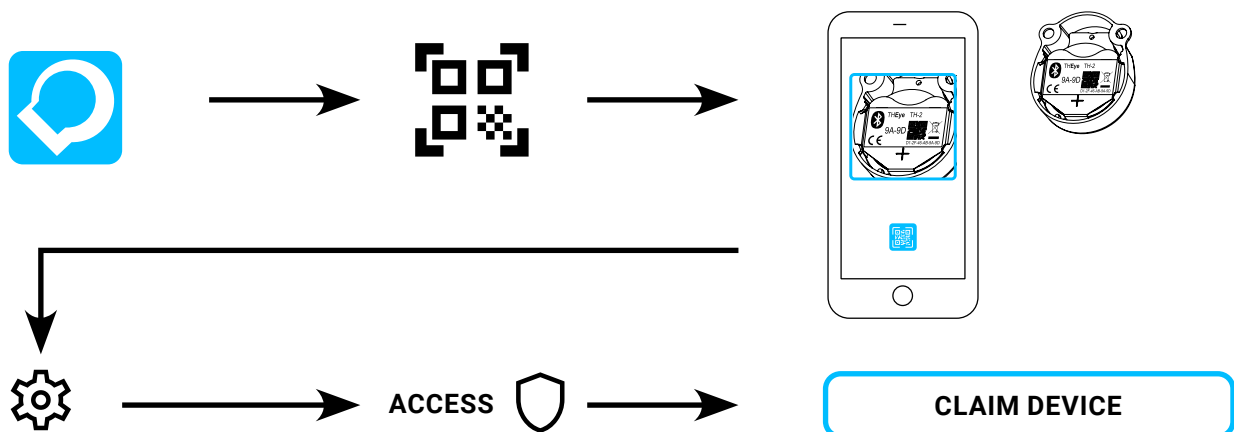

**i** In order to associate the THEye with your THEye Cloud account, it must not be associated with any other account. The OWNERSHIP STATUS field must be Free in PARAMETERS, ACCESS

**i** For security reasons, the application may ask to scan the THEye label a second time. Be sure to scan the label that is on the THEye.

## 1.3 Secure your data and view it on THEye Dashboard

- 1 Follow guide 1.2 if necessary.
- 2 Login to your module and upload the data to THEye Cloud

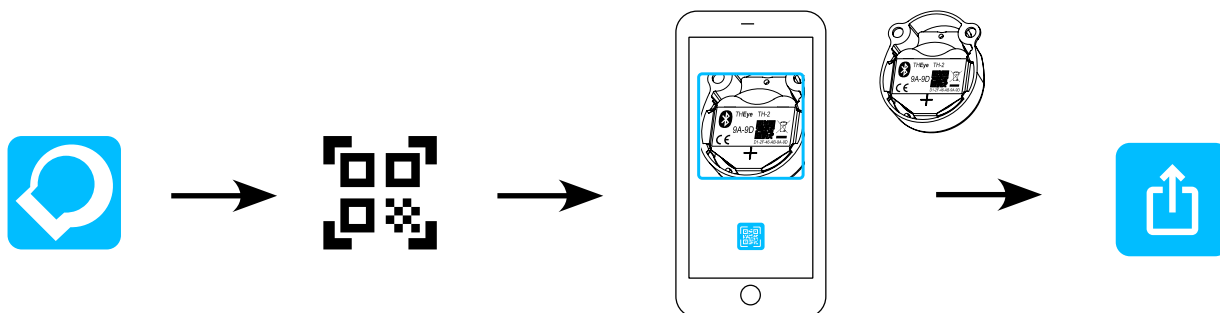

 If the upload button is grayed out it means that THEye is not associated with any account and THEye Cloud features are not available.

 Once THEye is associated with an account, uploading data is ALWAYS possible, regardless of the account used or the level of protection of THEye. On the other hand, the data is secured and can only be viewed by the associated account.

- 3 Go to THEye Dashboard

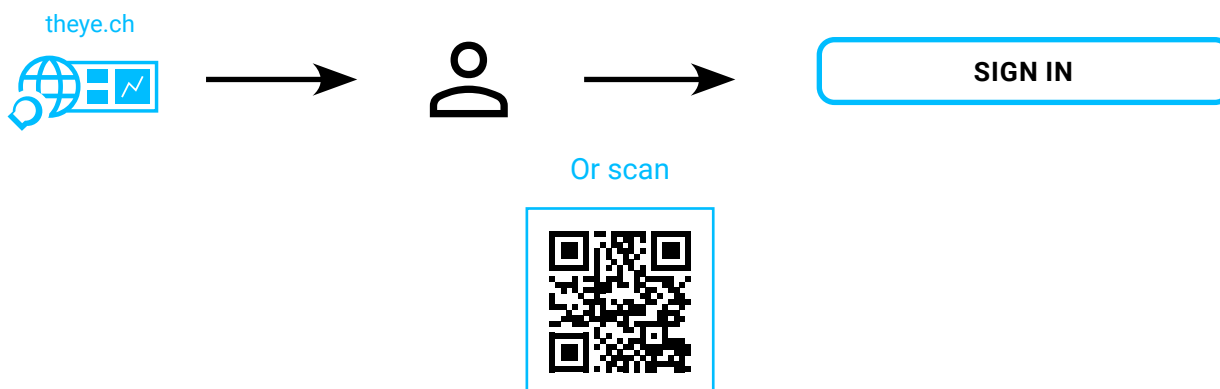

You will access your dashboard which has several menus:

- Devices : Access the THEye associated with your account
- Profile : Access your personal information

- 4 Select your THEye and view the records!

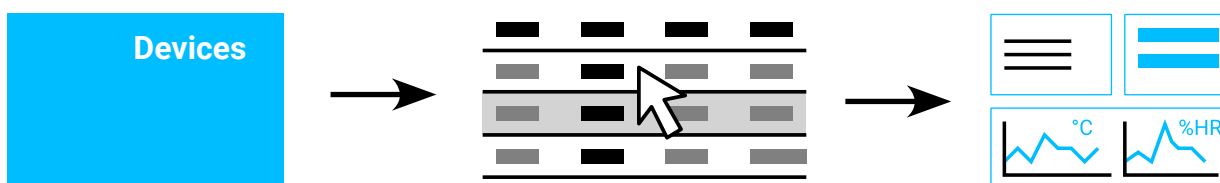

## 2. Technology

### 2.1 Overview of the technology

THEye is a compact temperature and humidity sensor that can record regular data over long periods of time in a secure manner. It has a battery life of up to 8 years. The Bluetooth® Low Energy communication allows to consult or retrieve the data with a smartphone and the application "THEye Controller". In addition, it can be linked to a cloud service "theye.ch" to secure the recorded data and configure its access level.

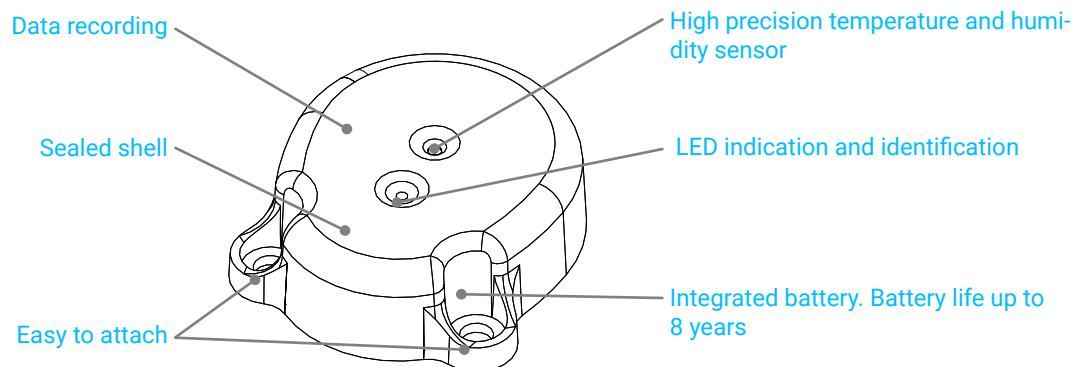

### 2.2 Use cases

THEye allows to monitor the environment, in case of storage or transport, of any material that may be sensitive to temperature and/or humidity. The data logging allows to know the history of the evolution of the environment in order to know if the material has been exposed to critical conditions.

The following is a non-exhaustive list of some frequently encountered uses of this sensor.

- Transport and storage of perishable goods (food, wine, tobacco, etc.)
- Transport and storage of sensitive products (medical, biological, etc.)
- Transport and storage of precious objects (furniture, paintings, musical instruments, etc.)
- Wireless measurement in sealed containers (laboratories, R&D, etc.)

### 2.3 Target audience

THEye is aimed at all entities for which the temperature and humidity of the environment are critical factors in the short, medium and long term and which require a means of monitoring these factors.





Our customers are mainly present in the following sectors of activity

- Transportation and warehousing
- Insurance
- Medical and biological
- Laboratories
- Research and development
- Metrology

## 3. THEye product range



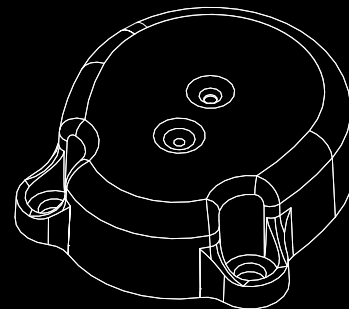

The THEye range currently includes two compact models, with high autonomy and extreme resistance.

### THEye TH-2

-  Humidity : 0 % to 100 %  $\pm 2$  %.
-  Temperature : -40°C to 70°C typical  $\pm 0.2$ °C
-  172'000 measurements points
-  8 years of autonomy with 1 measurement every 10 seconds
-  IP68, CE



### THEye TH-2 ISO

-  Humidity : 0 % to 100 %  $\pm 2$  %.
-  Temperature : -40°C to 70°C typical  $\pm 0.2$ °C
-  172'000 measurements points
-  8 years of autonomy with 1 measurement every 10 seconds
-  **EN12830**, IP68, CE

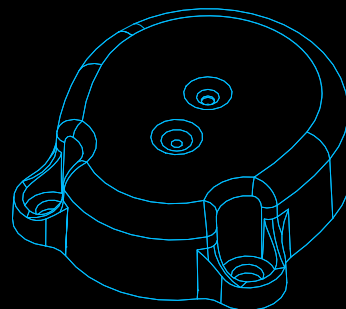

*The THEye TH-2 ISO model is EN12830 compliant (factory calibration, ISO/IEC 17025:2017 certificate available on request)*

## 4. THEye TH-2 and THEye TH-2 ISO

### 4.1 Characteristics

#### 4.1.1 Dimensions THEye TH-2 and THEye TH-2 ISO

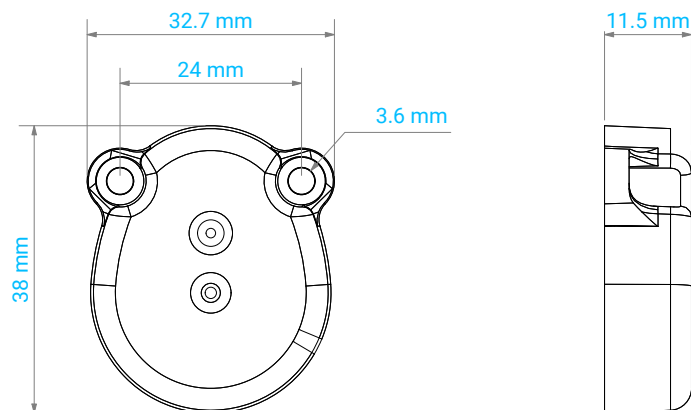

#### 4.1.2 Lifetime

THEye has been optimized for low consumption. It includes a non-removable battery that gives it a life of up to 8 years depending on its use and the conditions in which it is used.

Examples :

- Autonomy of 3.5 years with a measurement per second
- Autonomy of 8 years with a measurement every 10 seconds

More frequent measurements decrease the autonomy.

An active Bluetooth® connection with a smartphone also increases THEye's consumption and reduces its autonomy.

Using THEye outside the indicated temperature ranges can significantly reduce its autonomy.

#### 4.1.3 Memory

THEye uses a specific algorithm to compress the recorded data. The number of measurement points that can be stored in memory depends on the variations in humidity and temperature.

THEye can store a minimum of 172'000 humidity and temperature measurement points, i.e. a history of 120 days at a rate of one measurement per minute. For more details on the influence of the interval on the duration of the history, see point 5.4.1

Data compression is optimal if the variation between two measuring points remains between  $-0.20/+0.15$  %RH and  $-0.35/+0.30$  °C. The number of measurement points recorded can be up to 516,000 if the variations between two points remain within these ranges.

## 4.1.4 Measuring capacities and range of use THEye TH-2



Using THEye outside the indicated temperature range may alter its operation, cause irreversible damage and/or significantly reduce its life span.

Humidity			Temperature		
Range :		0%RH : 100%RH	Range :		-40°C : +70°C
Accuracy :	Typical	±2.0%RH (10%RH : 90%RH)	Accuracy :	Typical	±0.2°C (0°C : 65°C)
	Maximum	±4.5%RH (10%RH : 90%RH)		Maximum	±0.4°C (0°C : 65°C)
	Maximum	± 7.5%RH (<10%RH, >90%RH)		Maximum	±1.0°C (<0°C, >65°C)
Resolution :		0.06%RH	Resolution :		0.09°C
Drift :	Typical	<0.25 %RH/year	Drift :	Typical	<0.03 °C/year

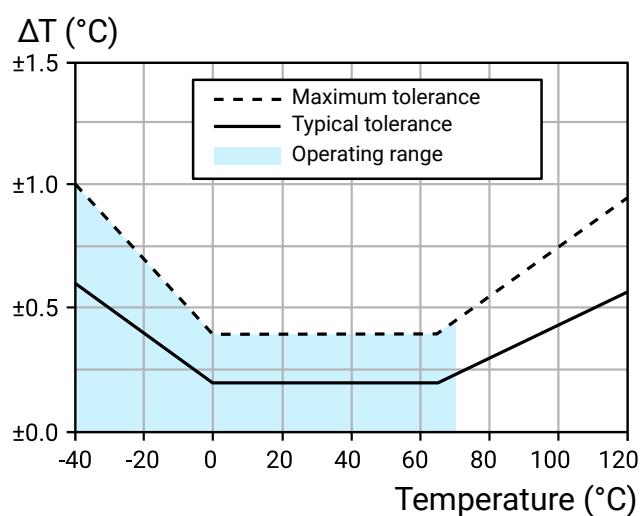
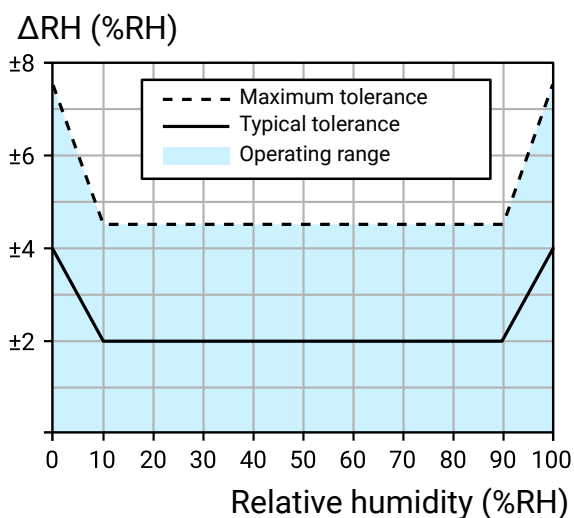

### 4.1.5 Measuring capacities and range of use THEye TH-2 ISO



Using THEye outside the indicated temperature range may alter its operation, cause irreversible damage and/or significantly reduce its life span.

Humidity			Temperature		
Range :		0%RH : 100%RH	Range :		-40°C : +70°C
Accuracy :	Typical	±2.0%RH (10%RH : 90%RH)	Accuracy :	Maximum	±0.48°C
	Maximum	±4.5%RH (10%RH : 90%RH)			
	Maximum	± 7.5%RH (<10%RH, >90%RH)			
Resolution :		0.06%RH	Resolution :		0.09°C
Drift :	Typical	<0.25 %RH/year	Drift :	Typical	<0.01 °C/year

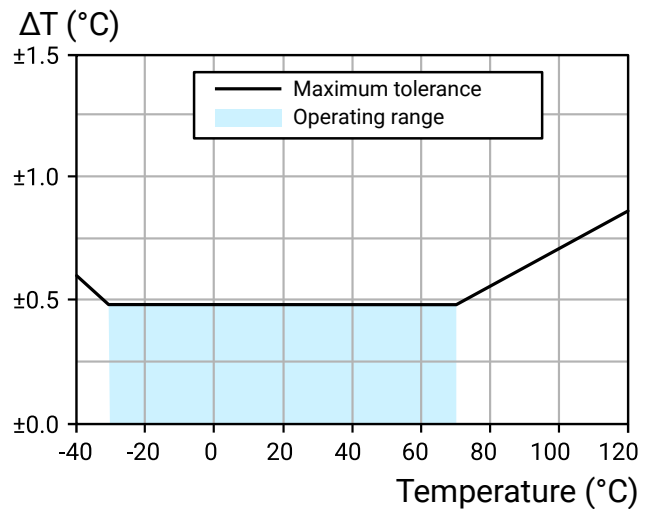
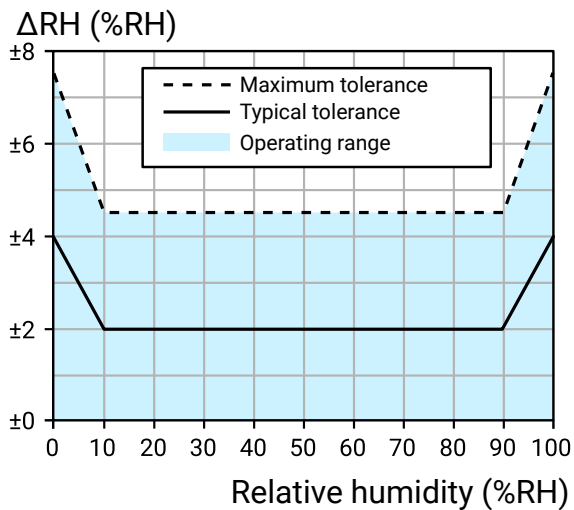

## 4.2 Time management

The THEye ecosystem is global. For this reason, the time scale for measurements is UTC (Universal Time Coordinated) and the time zone used internally is UTC±00:00.

### 4.2.1 Time zones

The conversion of the time into the user's time zone is performed by the THEye Controller application according to the smartphone settings and by the THEye Dashboard according to the user's settings.

### 4.2.2 Synchronization of the clocks

The THEye's internal clock is synchronized with the THEye Cloud clock through the creation of synchronization points. When creating a synchronization point, the time difference between the two clocks is 5 seconds maximum. In practice, it is of the order of 1 to 2 seconds depending on the conditions of the Internet network.

The internal clock of THEye undergoes a temporal drift which is more or less large according to the conditions of temperature.

Quartz characteristics:  $\pm 10$  ppm at 25°C,  $-0.03 \pm 0.01$  ppm/T2

The drift is typically :

- 0 seconds (0.9 seconds maximum) per day at 25°C.
- 1.6 seconds (3 seconds maximum) per day at 0°C or 50°C.
- 11 seconds (15.5 seconds maximum) per day at -40°C or 65°C.

A new synchronization point is initiated regularly and automatically to compensate for this drift.



*In order for a new synchronization point to be created automatically, a smartphone with an available internet connection must regularly connect to THEye through the THEye Controller application..*



*The consultation of the recordings on the THEye Controller application does not compensate for time drifts. The compensated recordings are available with the THEye Cloud service and can be viewed on the THEye Dashboard.*

### 4.2.3 Time correction

THEye uses an internal clock to measure time. This is subject to temporal drift, which can be partially compensated for by synchronization points. For further details, please refer to chapter 4.2.2

The dashboard displays data in three modes:

- Without compensation
- With « step » compensation
- With « linear interpolation » compensation.

In step compensation, the time drift accumulated by THEye is corrected in a single operation for each new synchronization point, as shown in the following figure.

Step compensation graphic :

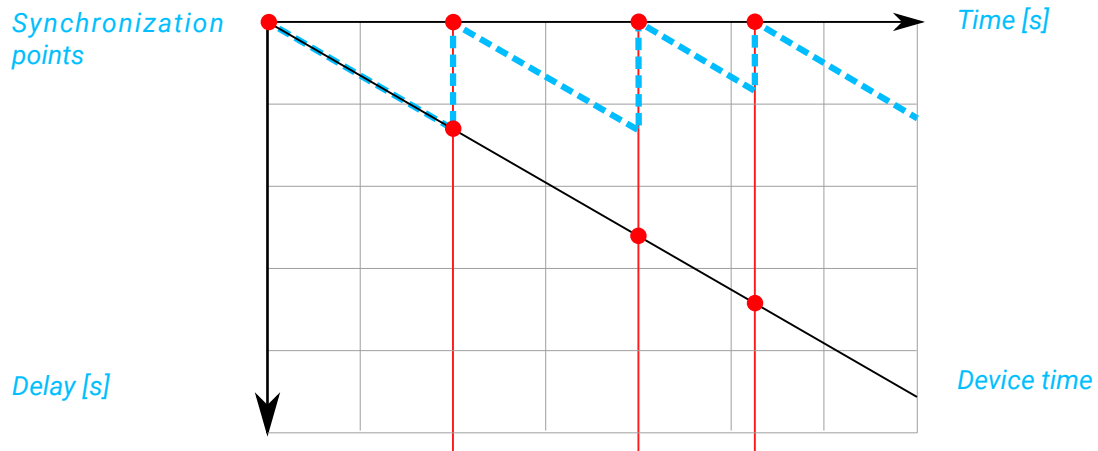

Linear compensation graphic :

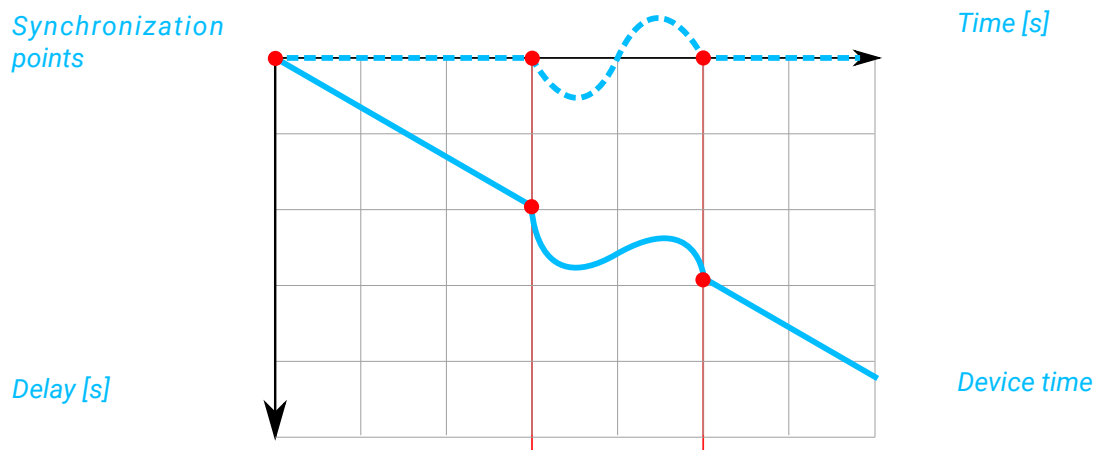

### 4.3 Bluetooth® communication

THEye has a Bluetooth® 5.0 Low Energy communication and is therefore compatible with all smartphones with this standard, using the application "THEye Controller".

The maximum connection range is 10 meters without obstacles.

## 4.4 Labels

There are three labels per THEye. The smallest (24x12 mm) is integrated in the module. The medium one (36x12 mm) is glued on the side of the packaging box. The large label (31x36 mm) is made available to the user for personal use.

**i** The labels contain a QR code with the THEye serial number. They facilitate the connection between the THEye Controller application and the THEye (see guide 1.1).

Module (24x12 mm)



Interior (31x36 mm)



Box (36x12 mm)



## 4.5 Packaging

The module is packed in a cardboard box with external dimensions of 14x40.5x35 mm, with THEye logo and a QR code referring to the product documentation website.

The package contains:

- 1x THEye module
- 1x Sticker 31x36 mm with the serial number of the module

On the side of the box there is a label with the serial number of the corresponding THEye module.

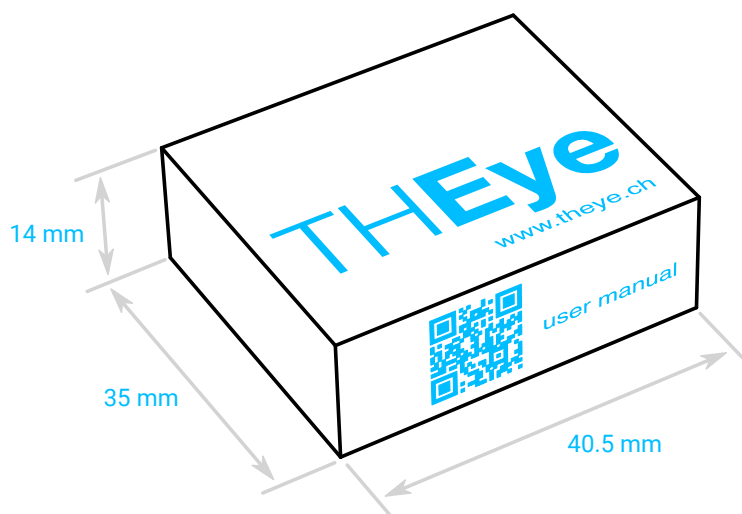

## 4.6 Installation

THEye should ideally be installed against a vertical wall or ceiling. It can be fixed with one or two screws (not included).

If the module is laid flat, dust can settle on the sensor over time and distort the measurements.

In any case, make sure that the opening at the temperature and humidity sensor is not covered.

Measurements will be inaccurate if the module is placed upside down or if the opening at the temperature and humidity sensor is not free.

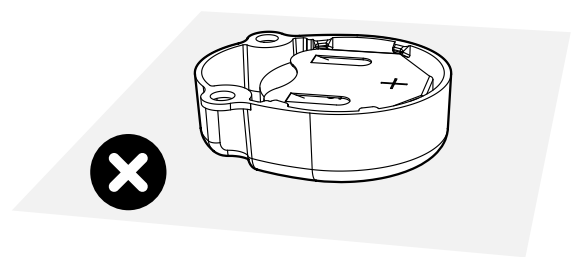
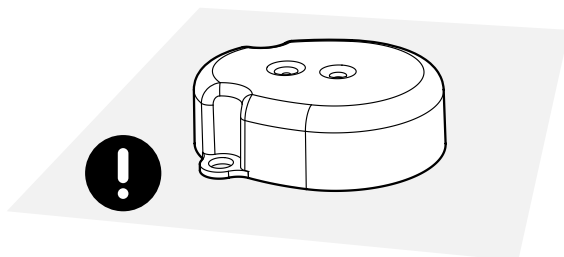
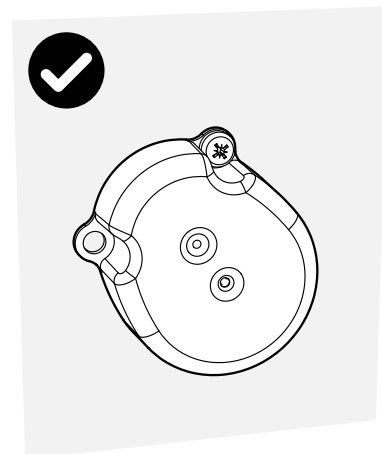
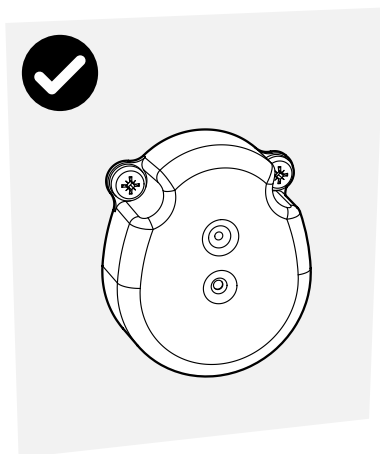
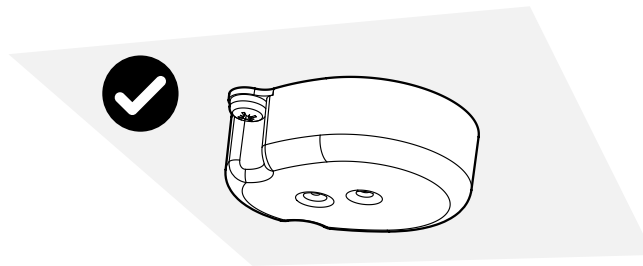

## 4.6.1 Where are THEye sensors to be installed?

"Informative" Level	Place 1x THEye in the center of the room, ideally under a table or storage area. See the storage warehouse example below: THEye n°1 is positioned in the center of the room.
"Storage" Level	Add 2x THEye on the floor facing north and 2x THEye on a shelf facing south. See the storage warehouse example below: THEye n°2 and 3 are positioned on the ground on the left, THEye n°3 and 4 are raised on the right.
"Room" Level	Add 4x THEye at the corners of the room, 2x on the floor to the north and another 2x raised to the south. See the storage warehouse example below: THEye n°6 and 7 are positioned at the corners and raised towards the South and THEye n°8 and 9 are at the corners on the ground towards the North.
"Opening" Level	Add 1x THEye at each opening, such as doors, windows (between the two hinges), vents. See the storage warehouse example below: THEye n°10 and 11 are positioned next to a door and n°12 is next to a window.
"Sun Option" Level	Add 1x THEye to each point of direct light, positioned at the center of the sun's projection at 3 p.m. See the storage warehouse example below: THEye n°13 is close to a window to catch the direct light.

Here's an example of a storage warehouse, 13x THEye have been strategically placed to ensure optimal monitoring, as well as instant, secure communication with the Gateway :

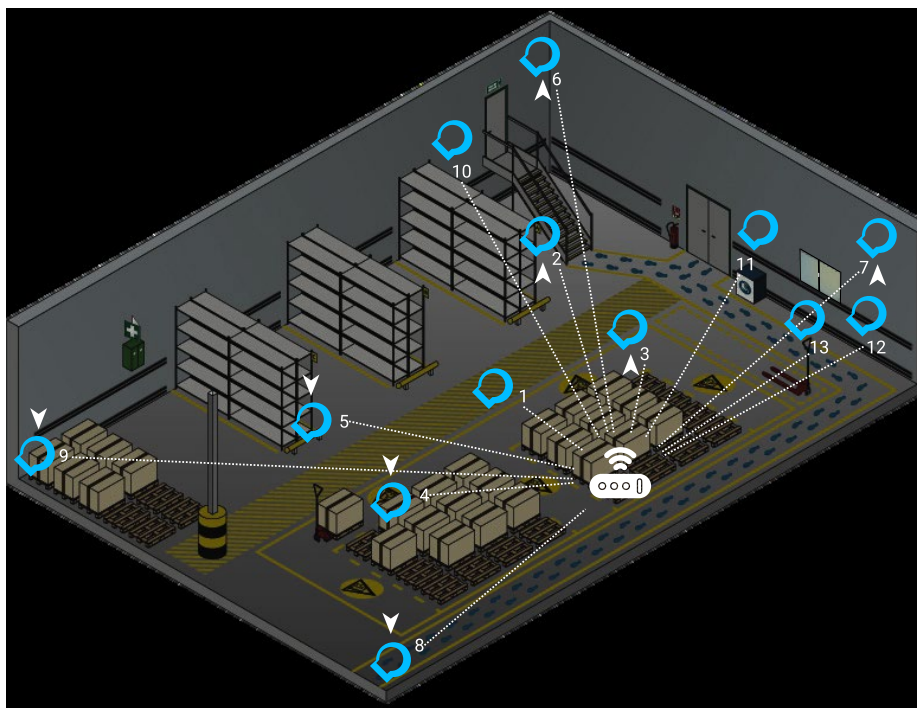

## 4.6.2 Usage Instructions and Limitations

Humidity and temperature sensors are highly accurate environmental sensors that require special care to ensure optimal performance. The sensors are susceptible to pollutants and must be protected from exposure to volatile chemicals, acids, bases, and cleaning agents. Especially Ketenes, Acetone, Ethanol, Isopropyl Alcohol, Toluene, etc.<sup>3</sup>, might cause drift, in some cases even irreversible. To ensure the sensors maintain their outstanding performance, it is important to follow these guidelines:

- Avoid exposing the sensor to pollutants, especially volatile chemicals such as solvents or organic compounds. High concentrations and long exposures should be avoided, as they can cause drift in the humidity reading or even irreversibly damage the sensor.
- Be aware that certain chemicals are often found in epoxies, glues, adhesives, and plastics, and may outgas during baking and curing, potentially affecting the sensor.
- Avoid contact with cleaning agents, such as PCB board wash after soldering, or strong air blasts from an air-pistol<sup>4</sup>, as they can cause drift in the reading or complete breakdown of the sensor.
- Ensure good ventilation to avoid high concentrations of volatile chemicals, such as solvents, cleaning solutions, and detergents, e.g. ethanol, isopropanol, methanol, acetone, etc.

When packaging sensors, it is important to ensure that the materials used do not have the potential to cause sensor pollution. To maintain the accuracy and longevity of your sensors, only use packaging materials that do not outgas.

Metal-in antistatic shielded ESD bags, paper or cardboards based packaging, and deep-drawn plastic trays such as PE, PET, and PP may be considered. Do not use antistatic polyethylene bags, bubble foils, and foams, as they may contaminate the sensor. Additionally, be cautious when using stickers inside the packaging, as they can also cause contamination if not used properly. Sticker size should be kept to a minimum, and the sticky side should fully adhere to a surface.

It is important to note that many packaging materials may contain additives (plasticizers) that can have a polluting effect on the sensor. As a general rule, if a material emits a strong odour, it should not be used. Additionally, even materials that are recommended for use may contain additives, so it is important to be aware of this when selecting packaging materials.

## 5. THEye Controller

### 5.1 Downloading and installation

The "THEye Controller" application is available for download on Google Play (Android) and App Store (iOS) at the following links :



<https://play.google.com/store/apps/details?id=ch.fiveco.bttemphum>











[https://apps.apple.com/us/app/theye-controller/id1540575481?itsct=apps\\_box\\_badge&itscg=30200](https://apps.apple.com/us/app/theye-controller/id1540575481?itsct=apps_box_badge&itscg=30200)





*In order to activate the Bluetooth® features, the app asks for permissions when it first starts up. It is necessary to accept all authorizations for the application to work properly.*

## 5.2 Symbols

Symbols	Name	Description / Function
	Application info	Clicking on the icon opens a window with the application information (version, copyright, privacy policy).
	Access to local logs	Allows access to logs previously retrieved from THEye and stored locally on the smartphone.
	Not authenticated	Click on the icon to initiate the user authentication procedure.
	Authenticated	Click on the icon to access the profile information.
	User	Represents the user of the associated account.
	Logout	Allows you to disconnect the user account.
NOM	Sorting by name	Allows you to sort the list by the local name of the THEye.
RSSI	Sorting by RSSI	Allows you to sort the list by RSSI (Receive Signal Strength Indication), i.e. the strength of the BLE signal received by the application.
T°C	Sorting by temperature	Allows you to sort the list by temperature measured in degrees Celsius.
T°F	Sorting by temperature	Allows you to sort the list by temperature measured in degrees Fahrenheit.
%HR	Sorting by relative humidity percentage	Allows you to sort the list by relative humidity measured in percent.
	RSSI: Weak Signal	Symbolizes a weak Bluetooth® signal (< -80 dBm).
	RSSI : Medium Signal	Symbolizes a medium Bluetooth® signal (< -60 dBm).
	RSSI: Strong Signal	Symbolizes a strong Bluetooth® signal (>= -60 dBm).

Symbols	Name	Description / Function
	Bluetooth® Scan	A click on the icon allows the discovery of THEye devices in the vicinity during 30 seconds.
	Connection by QR code	Clicking on the icon starts the connection procedure by scanning the QR code.
	The THEye is free	The THEye is not associated with a THEye Cloud account.
	The THEye is not free	The THEye is associated with a THEye Cloud account.
	Battery full	The THEye's charge reserve is full.
	Battery average	The THEye's charge reserve is medium.
	Low battery	The THEye's charge reserve is low.
	Logs	Clicking on the icon gives access to the logs in the THEye's memory.
	Location	A click on the icon allows you to locate the THEye by making its red LED flash 3 times.
	Sharing	A click on the icon allows you to share the data in the THEye's memory by email.
	Uploading	A click on the icon allows you to upload data from the THEye memory to the THEye cloud in a secure way.
	Settings	A click on the icon allows you to access the THEye parameters.
	Measurement parameters	Click on the icon to access the THEye measurement parameters.
	Alarm parameters	A click on the icon gives you access to THEye alarm settings.

Symbols	Name	Description / Function
	Information parameters	Click on the icon to access the THEye information parameters.
	Access parameters	A click on the icon gives access to the access parameters of THEye.

---

## 5.3 Application pages

The THEye Controller application is divided into three groups of pages:

- The Home page allows you to search for THEye in your vicinity and to initiate a connection with a THEye.
- The Device page allows you to view the status of the THEye, the currently measured values and to view the history.
- The Parameters pages allow you to set up the THEye, i.e. the parameters of the recording (measurement interval), its accesses etc.

### 5.3.1 Home Page

The Home page allows you to start searching for THEye in your vicinity and to initiate a connection with one of them.

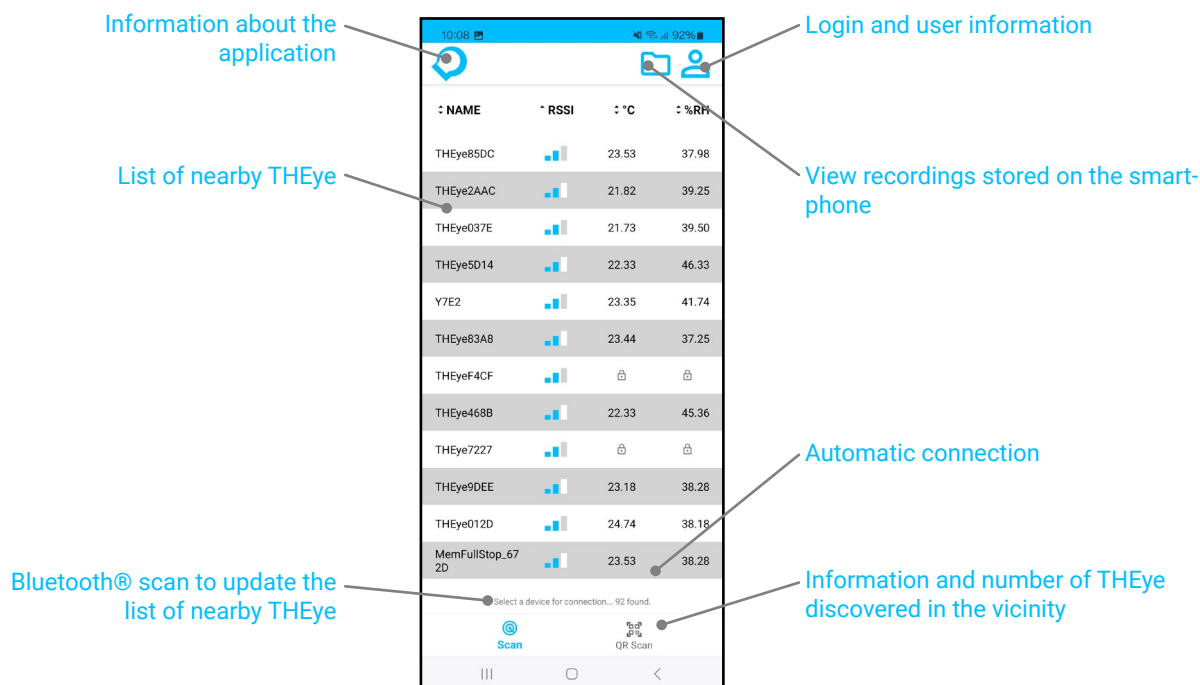





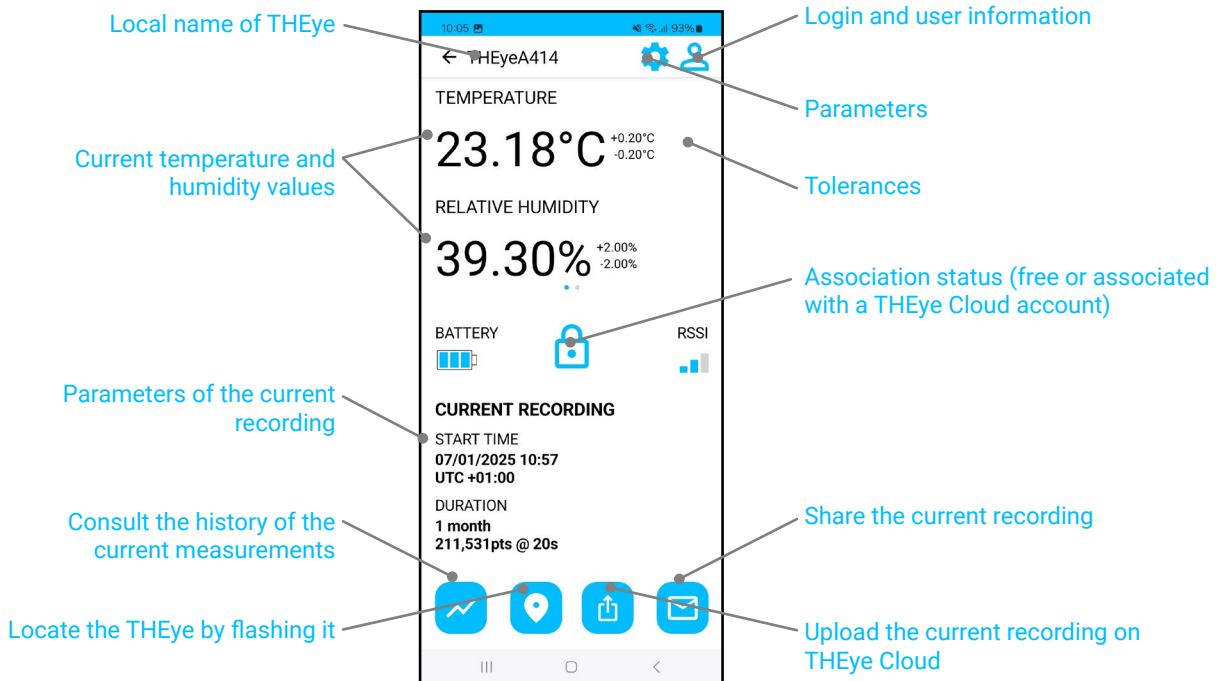

Depending on the configuration of the THEye (see point 6.2), it is possible that the temperature and humidity do not appear in the list of Bluetooth® scan results.

### 5.3.2 Device page

The device page allows you to view the current data record at a glance and to view the status of the current recording.



-  *The THEye Controller application only allows you to connect to one THEye at a time.*
-  *The measurement tolerances are the typical tolerances. They depend on the absolute value of the measurement and the time (see points 4.1.4 and 4.1.5).*
-  *The association status indicates whether THEye is free or associated with a THEye Cloud account. See guide 1.2 to associate the THEye to a THEye Cloud account.*
-  *The first name seen on a device is cached by iOS, and there is currently no way to force it to update.*
-  *Depending on the configuration of THEye (see point 6.2), some values and functions may not be available.*
-  *The share button allows you to download the data from the THEye memory and send them in .csv format by email.*

## 5.3.3 Parameter pages

### Measurement parameters

The "Measurements" parameter page allows you to start a new recording sequence.



*When a new recording sequence starts, all the measurements stored on THEye are no longer accessible. To access this data later, be sure to collect the current recording, share it via email, or upload it to the THEye Cloud.*

Start a new recording

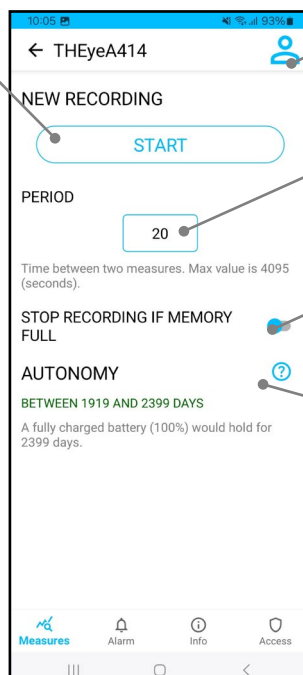

Login and user information

Selection of the time interval between two measurements

Selection of the behavior in case of THEye memory overflow

Information about the autonomy of the THEye



*The measurement interval has an influence on the lifetime of the THEye and the time until the internal memory of the THEye is filled. See point 5.4.1*



*The parameter "Stop recording if memory full" allows you to define the behavior of the THEye when the recording occupies the entire memory of the THEye. See point 5.4.1*

## Alarm settings

The "Alarm" parameter page allows you to define or redefine upper and lower limits for temperature and humidity. When a limit is exceeded, THEye goes into "alert" mode. The alert mode is characterized by the following behaviors:

- The THEye LED flashes twice every 5 seconds.
- The THEye and the temperature and humidity values are in red in the list of devices near the home page.
- The words Temperature and Relative Humidity are blinking in red in the Device page.

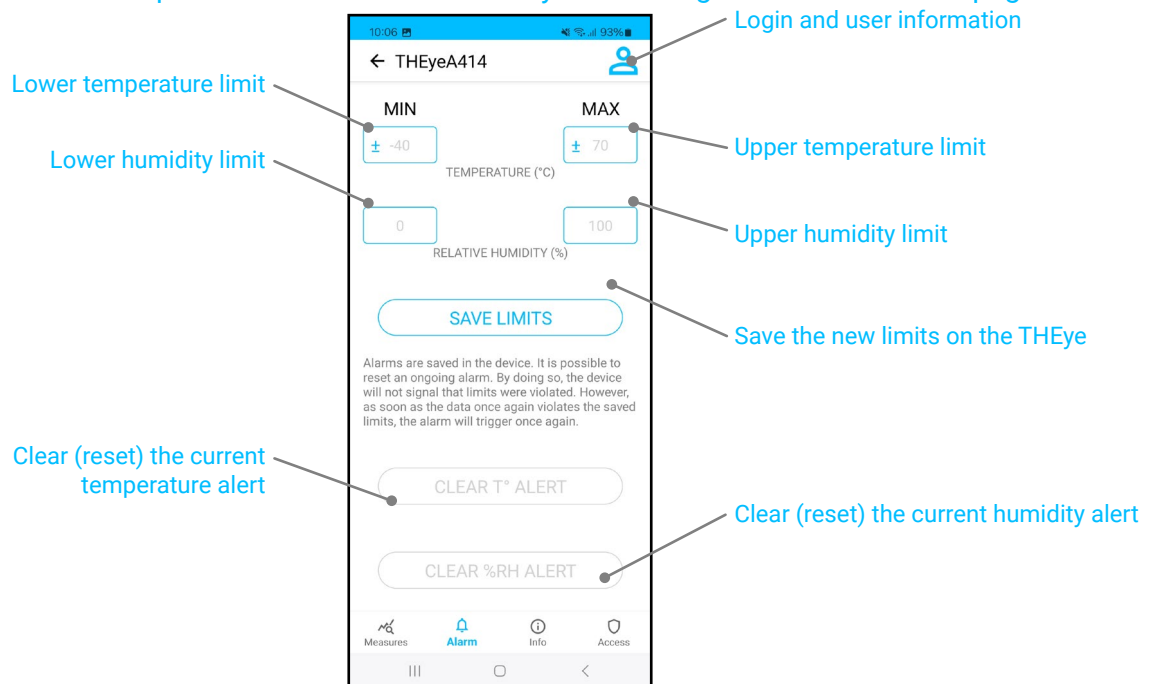





 Depending on the configuration of THEye (see point 6.2), the temperature and humidity may not appear in the Bluetooth® scan result list.

 Setting the limits to their maximum values (-46°C, +128°C, 0%RH, 100%RH) disables the alarm system.

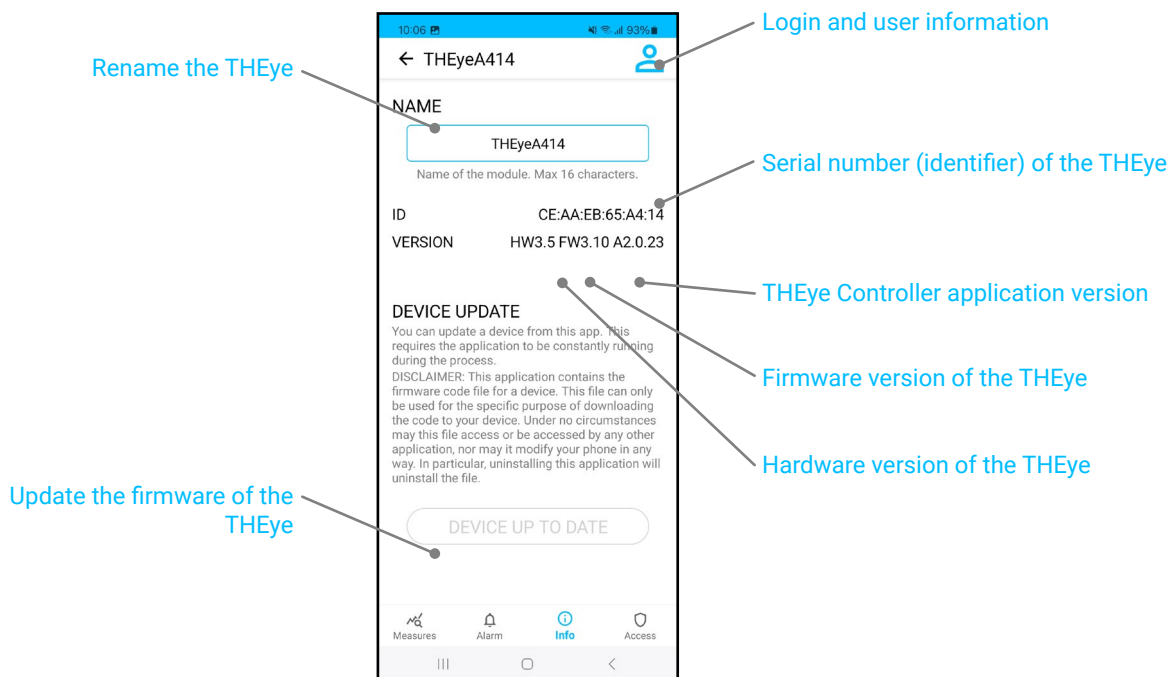
## Information settings

The "Information" parameter page gathers the elements for identifying and updating THEye.



-  *The THEye can be renamed and can contain up to 16 characters. If the name ends with groups of two sharps (##), these will be automatically replaced by the last values of the serial number. For example "THEye####" becomes THEyeF8BC and "House ##" becomes "House BC".*
-  *If a new firmware version of THEye is available, it can be installed on THEye by clicking the "Update" button. Data from the current recording may be lost! Be sure, if needed, to collect the current recording, share it via email or upload it to the THEye Cloud.*
-  *Depending on the configuration of THEye (see point 6.2), temperature and humidity may not appear in the Bluetooth® scan result list.*

## Access settings

The "Access" parameter page allows you to associate the THEye with a THEye Cloud account. In addition, for a THEye associated with a THEye Cloud account, it allows you to customize the THEye's access for other users according to several configurations.

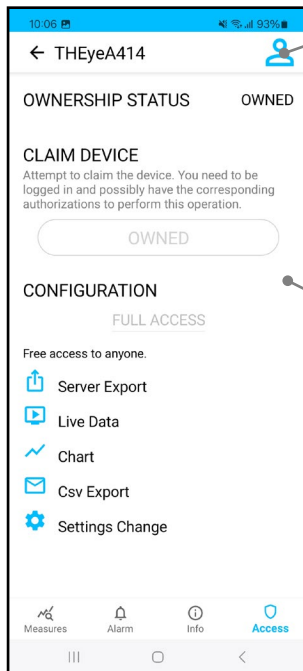

Login and user information

Association of THEye with the THEye cloud account

Selecting the THEye access configuration for other users

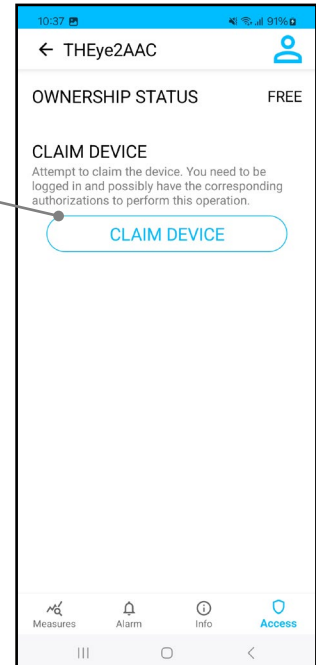

The description of THEye access configurations is available in section 6.2.



To disassociate a THEye from a THEye Cloud account, go to the THEye Dashboard and use the "release" function of a THEye (see point 7.1.1)

## 5.4 Features

### 5.4.1 Start a new recording



*When a new recording sequence starts, all the measurements stored on the THEye are no longer accessible. To access this data later, be sure to paste the current recording, share it by email or upload it to the THEye Cloud.*

When starting a new recording, it is possible to set the measurement interval and the behavior in case of full memory.

#### Measurement interval

It defines the time between two measurements in seconds. Although a small interval between two measurements allows a fine view of the history, it comes with some disadvantages:

	Small interval	Large interval
Time resolution	+	-
Lifetime (battery)	-	+
Duration of the history in autonomy	-	+
Time of collection and transfer of measurements	-	+

The THEye being in standby between each measurement, a small interval strongly decreases the global standby time and consequently increases the average consumption of the module.

The THEye's memory being limited (172'000 points), it reaches saturation more quickly with a short interval. The duration of the history in autonomy (without the data being collected with the THEye Controller) is therefore lower with a small interval.

Representing the history of a period with a small interval considerably increases the amount of data to be processed and consequently increases download times, storage memory on the smartphone, etc.

Examples:

Interval	1s	10s	1min	10min (default)
Lifetime	3.5 years	8 years	9 years	9 years
Duration of the history in autonomy	1 day and 21 hours	19 days and 21 hours	119 days	3 years and 98 days
Number of points after 1 year	31.5 millions	3.15 millions	525'600	52'560

## Stop recording if memory full

This parameter allows you to define the behavior of THEye when the recording occupies the whole memory.

By default, the behavior when the memory is full is to overwrite the oldest measurements with the most recent measurements. The measurement history is therefore "sliding" with the passing of time and data cannot be collected further back than the duration of the THEye's autonomous history.

When the "Stop recording if memory full" option is activated, THEye will simply stop recording measurements when the memory is full. This behavior preserves the measurements from the beginning of the recording and prevents them from being overwritten inadvertently.



*Using the THEye Cloud service allows, by regularly collecting data with the THEye Controller, to keep the entire measurement history, regardless of the selected measurement interval.*

## THEye location

By pressing the location button, the connected THEye identifies itself by flashing its indicator LED three times. The LED is located on the top of the THEye under the white translucent shell.

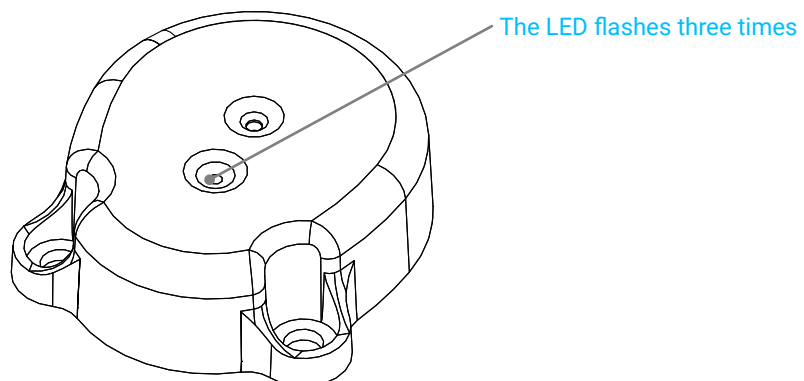

## Dew point calculation

The dew point is calculated by the THEye Controller application from the current measured temperature and humidity values. The equation used is the following (approximation of Heinrich Gustav Magnus-Tetens):

$$T_{dp} = \frac{c \cdot \ln\left(\frac{HR}{100}\right) + \frac{b \cdot T}{c+T}}{b - \ln\left(\frac{HR}{100}\right) - \frac{b \cdot T}{c+T}}$$

With

$T_{dp}$  Dew point [°C]

$T$  Temperature [°C]

$HR$  Relative Humidity [%]

$b$  17.62

$c$  243.12 [°C]

### 5.4.2 Sharing the recording by email

The data collected by THEye can be retrieved and sent by email for further processing and consultation.

#### Structure

When sharing the recording by email, a .csv file (comma-separated-values) is transmitted. The delimiter used is the semicolon ";" and the structure is composed of three data blocks:

---

Line 1: Recording info header  
Line 2: Recording information

---

Line 3: Header of limits  
Line 4: Limits

---

Line 5: Values header  
Line >6 : Values

---

## Example of the structure of the .csv file

### Recording information

	1	2	3	4
1	Device Name	Timezone	First Timestamp	Last Timestamp
2	THEyeF8BC	UTC+01:00	26.10.20022 10:10:00	28.10.20022 10:20:50

### Limits

	1	2	3	4
3	Lower Temperature Limit (°C)	Upper Temperature Limit (°C)	Lower Humidity Limit (%RH)	Upper Humidity Limit (%RH)
4	12	19	20	30

### Values

	1	2	3	4	5	6	7
5	ID	Imprecise Time	Temperature Alert	Humidity Alert	Timestamp	Temperature (°C)	Humidity (%)
6	0	False	True	False	26.10.20022 10:10:00	27.55	25
7	1	False	True	False	26.10.20022 10:10:10	27.0	25
...	...	...	...	...	...	...	...

## 6. THEye Cloud

The THEye Cloud service is an online service offering the following features :

- Add an authentication system with accounts to secure access to THEye (locking of recording parameters, visibility of measurements, etc.)
- Secure and archive THEye data on Swiss servers.
- Remotely consult the recordings through the THEye Dashboard.



### 6.1 Encryption, data integrity

 *In general, all communications with THEye Cloud are encrypted using standard web security protocols (TLS/SSL).*

To ensure the protection (theft) and integrity (corruption) of the recordings, a secret key is shared between THEye and THEye Cloud.

The record transfers between the THEye Cloud and the server are encrypted with the secret key according to the AES standard and are therefore unreadable by the THEye Controller or any other malicious application.

In addition, a digital fingerprint (hash) of the records is transmitted and allows to verify the integrity of the transferred data.

### 6.2 THEye is secured by the THEye Cloud account

When THEye is associated with a THEye Cloud account, THEye access for other users can be customized (see 5.3.3) according to the following four configurations:

- **Full access** : Access to all THEye values and settings.
- **Limited access** : Access to all THEye values and parameters that cannot compromise the current recording.
- **Live** : Access to all current (live) values of the THEye. Does not allow to see the history and to compromise the current recording.
- **Protected (Default)** : No access to the values and parameters of THEye. However, the user can upload the encrypted recording to the THEye cloud. This configuration allows an anonymous user to collect the recordings for the THEye associated account without having access to the data.

Configuration		Full access	Limited access	Live	Protected (Default)
BLE Advertisement	Temperature visible when scanning devices.	✓	✓	✓	X
	Humidity visible when scanning devices.	✓	✓	✓	X
	Battery status visible when scanning devices.	✓	✓	✓	X
	Limit violation alerts visible when scanning devices.	✓	✓	✓	X
Connection to THEye	Sending the encrypted recording to the THEye Cloud.	✓	✓	✓	✓
	Locate THEye with flashing LED.	✓	✓	✓	✓
	Current temperature visible when connecting to a device.	✓	✓	✓	X
	Current humidity visible when connecting to a device.	✓	✓	✓	X
	Current battery status visible when connecting to a device.	✓	✓	✓	X
	Alerts visible when connecting to a device.	✓	✓	✓	X
	The humidity overlimit alert can be reset.	✓	✓	X	X
	The temperature limit violation alert can be reset.	✓	✓	X	X
	Playback of the recording from the THEye Controller application.	✓	✓	X	X
	Updating the THEye firmware.	✓	X	X	X
	Setting the temperature limits.	✓	X	X	X
	Setting of humidity limits.	✓	X	X	X
	Change the local name of the device.	✓	X	X	X
	Configuration and start of a new registration.	✓	X	X	X

## 6.3 Subscriptions and prices

The THEye Cloud service requires the creation of a THEye Cloud account. Several plans are available, including the free plan that allows access to the basic features of the service.

	BEGINNER	BASIC	PRO	BUSINESS
Number of organizations in the account	0	1	1	unlimited
Number of members in the organizations	-	up to 5	up to 50	unlimited
Number of THEye associated with the account	1	up to 100	up to 1'000	unlimited
Access to the data	last 31 days	unlimited	unlimited	unlimited
Viewing graphs with zoom	yes	yes	yes	yes
Locking of THEye associated to the account	yes	yes	yes	yes
Sending an email when new data has arrived on the server	no	yes	yes	yes
Digitally signed certificate	no	no	yes	yes
Export of *.csv and *.xlsx spreadsheets	no	no	yes	yes
Graph overlay from multiple devices	no	no	yes	yes
Advanced email system (limit violations, changes in THEye settings, etc.)	no	no	yes	yes
Price	Free	see <a href="https://theye.ch/pricing">theye.ch/pricing</a>		

## 7. THEye Dashboard

The THEye Cloud service is accessible through a user-friendly web interface, the THEye Dashboard. To access it, you can follow the guide 1.3.

### 7.1 Record review page

The THEye record review page is composed of three areas:

- Information area of THEye.
- Records list area.
- Charts area.

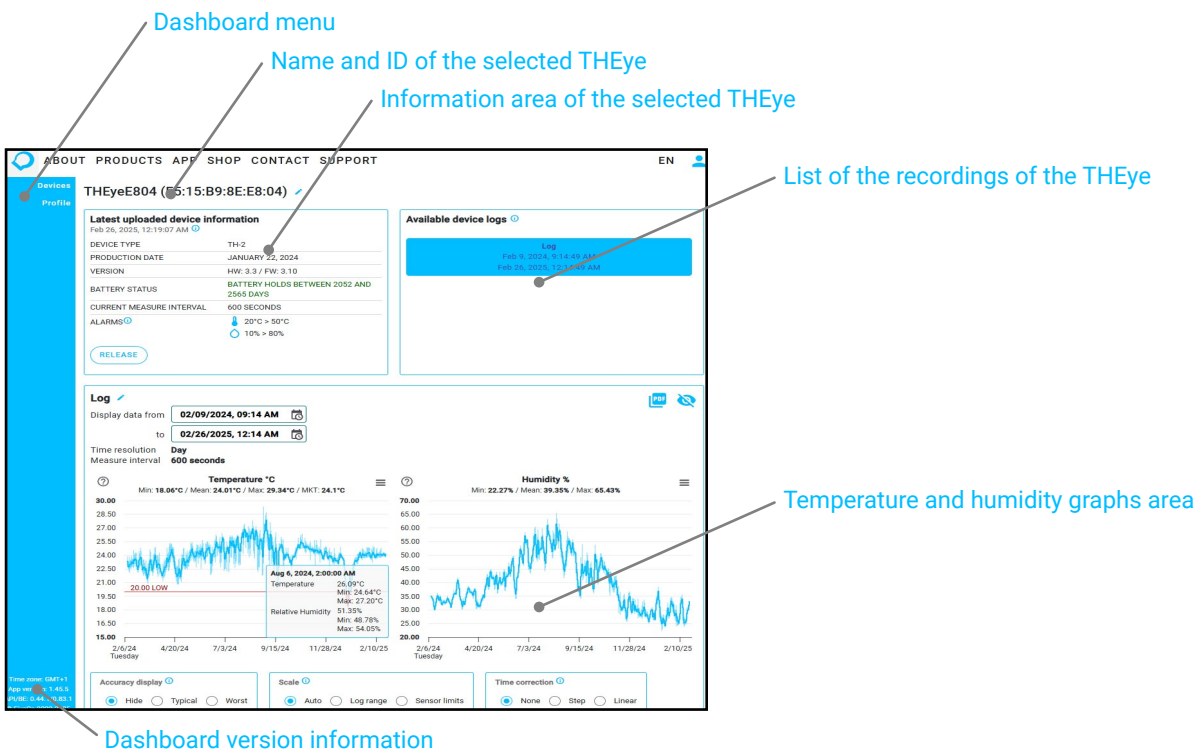

The screenshot displays the THEye Dashboard interface. At the top, there is a navigation menu with options: ABOUT, PRODUCTS, APP, SHOP, CONTACT, SUPPORT. Below this, the 'Devices profile' section shows the selected device 'THEyeE804 (E5:15:B9:8E:E8:04)'. The 'Latest uploaded device information' section provides details such as Device Type (TH-2), Production Date (JANUARY 22, 2024), Version (HW: 3.3 / FW: 3.10), Battery Status (BATTERY HOLDS BETWEEN 2032 AND 2565 DAYS), Current Measure Interval (600 SECONDS), and Alarms (20°C > 50°C, 10% > 80%). A 'RELEASE' button is visible. The 'Available device logs' section shows a list of recordings with a 'Log' button. The 'Log' section displays data from 02/09/2024, 09:14 AM to 02/26/2025, 12:14 AM, with a time resolution of Day and a measure interval of 600 seconds. Two graphs are shown: Temperature °C (Min: 18.06°C, Mean: 24.01°C, Max: 29.34°C, MKT: 24.1°C) and Humidity % (Min: 22.27%, Mean: 39.35%, Max: 65.43%). A specific recording on Aug 6, 2024, at 2:00:00 AM is highlighted, showing Temperature: 26.09°C, Humidity: 51.33%, and a '20.00 LOW' alarm. The bottom of the dashboard includes 'Accuracy display' (Hide, Typical, Worst), 'Scale' (Auto, Log range, Sensor limits), and 'Time correction' (None, Stop, Linear) options. A footer section shows 'Free zone: 0471-1', 'Page no: 11, 14, 15', and 'Page: 3, 44, 45, 51, 1'.

#### 7.1.1 Information area on the selected THEye

This area gathers the information specific to the selected THEye. It also allows you to perform the following two actions.

##### Rename

Allows you to change the name of the THEye used on the Dashboard.



*The name used on the THEye Dashboard is an alias to facilitate the organization of the THEye on the Dashboard. This alias is independent of the name registered on the THEye thanks to the THEye Controller application (see 0).*

## Release

Allows you to dissociate the THEye from the associated THEye Cloud account. The THEye is no longer protected and becomes available again to any user. To re-associate the THEye to a new account you have to follow the guide 1.2 again.



The recordings that are not deleted will be available to the next user who associates the THEye with his THEye Cloud account.

### 7.1.2 Recording list area

This area allows you to view the available recordings and select the recording that will be displayed in the charts area.

### 7.1.3 Charts area.

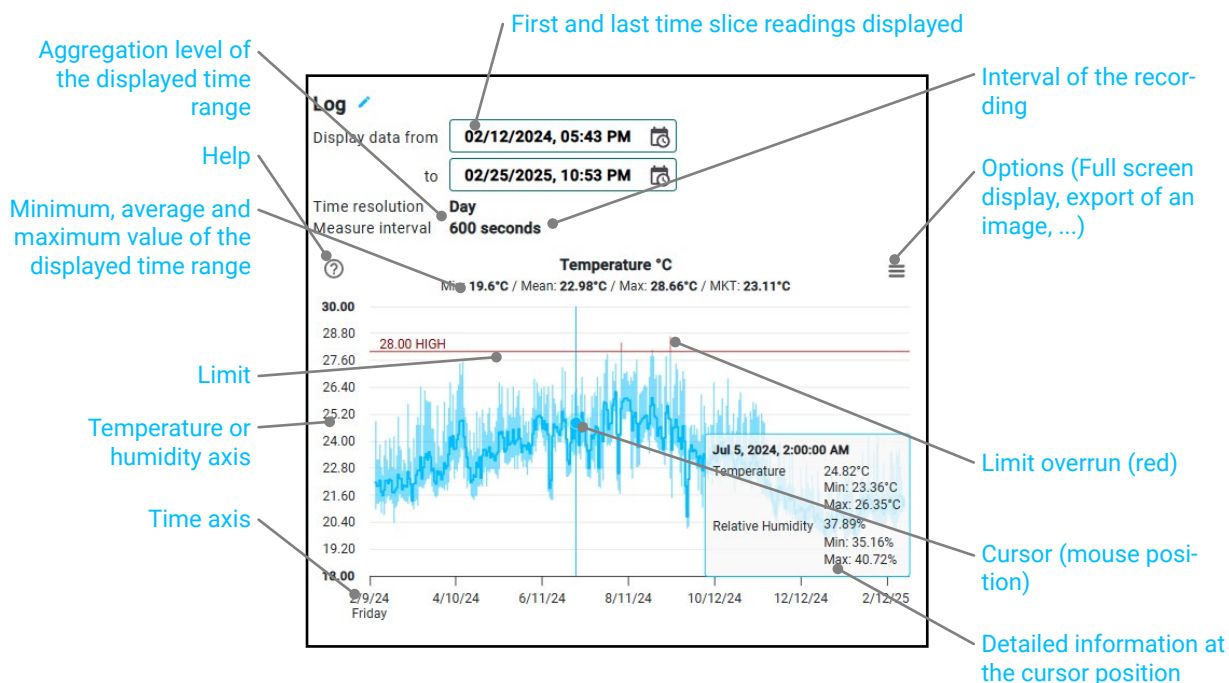

### Adjustment of the time scale

To adjust the time scale, simply make a rectangular selection on the area of interest with the mouse (or zoom with two fingers in the case of a smartphone or tablet).

### Adjusting the vertical scale

To adjust the vertical scale, three modes are available:

- Auto: The vertical scale adapts to the data displayed
- Log range: The vertical scale adapts to the data of the entire log
- Sensor limit: The vertical scale adapts to the range of use of the THEye.

## Time resolution (or aggregation level)

Time series, (such as temperature or humidity recordings) usually generate a large amount of data. As an example, a survey every 10 seconds produces 3.15 million points in one year. In order to be able to quickly consult the data, aggregates are built by THEye Cloud for each of the following levels:

- Second
- Minute
- Hour
- Day
- Month
- Year

Thus, the representation of a year with a recording every 10 seconds is composed of 52'560 points in the minutes aggregate, 876 points in the hours aggregate and only 36 points in the days aggregate.

Depending on the time range to be displayed, the most suitable aggregate will automatically be used. The selected level is displayed in the "Time resolution" field of the graph area.

## Calculation of aggregates, averages and extreme values

A point in an aggregate is represented by three values: the average, minimum and maximum of the points contained in the interval of the aggregate level. For example, a point in the minutes aggregate contains the average, the maximum and the minimum of all points contained in the represented minute.

While the average value is a fairly good representation of the readings contained in a point in the aggregate, it can hide abnormal values. This is why the minimum and maximum values are also present to avoid missing critical information.

For example, consider the following table:

Readings							Aggregate minute		
0s	10s	20s	30s	40s	50s	60s	Average	Minimum	Maximum
25°C	26°C	24°C	35°C	26°C	15°C	24°C	25°C	15°C	35°C

In this example, the average of the readings for the minute shown is 25°C. This may seem like a normal value, but it does not account for the large variations in seconds 30 and 50. The minimum and maximum values of the aggregate therefore allow the abnormal variations to be visualized instantly.

Graphically, the average value is represented by a blue line and the maximum and minimum values by a blue band.

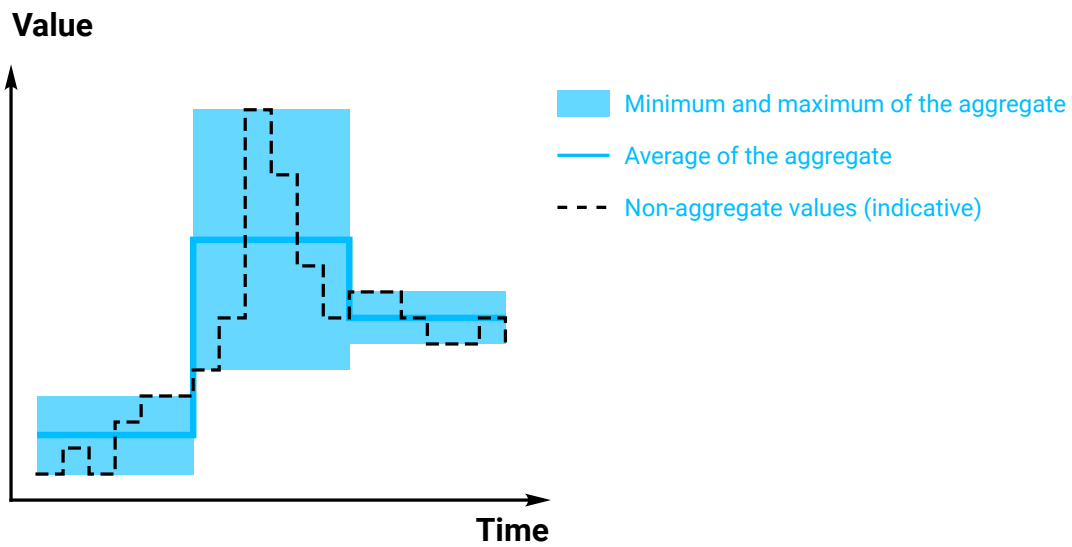

## Tolerances

The temperature and humidity values measured by the sensor have inaccuracies (see 4.1.4 and 4.1.5). The typical and maximum tolerances of the sensor are also shown on the graph with a lighter blue area.

The simultaneous display of an aggregate and the tolerances is represented by two blue bands of different intensity.

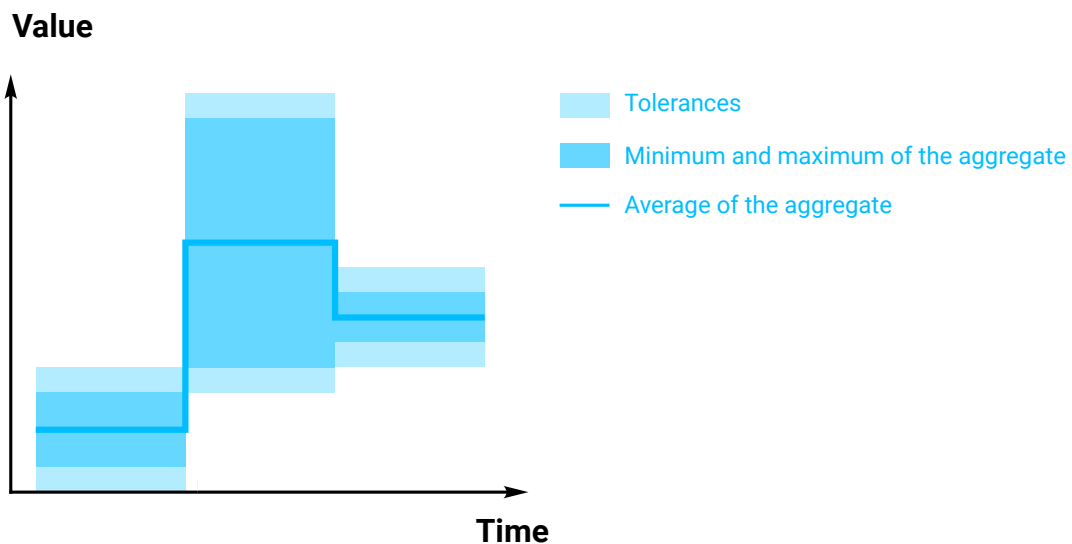

## 8. THEye Gateway

The THEye Gateway is a device used to automatically download data from nearby THEyes and transfer it to the server. In addition, an audible alarm alerts the user when one or more THEye devices record out-of-limit values (specified with the smartphone app). It is easily configured using THEye Controller smartphone app.

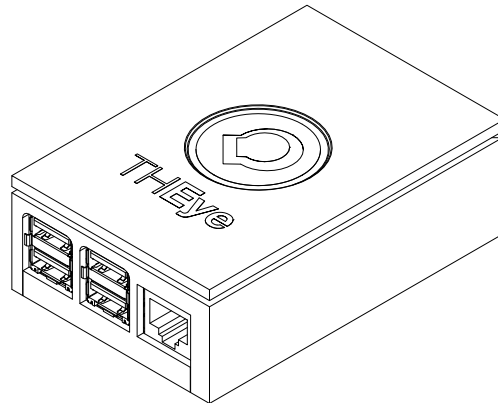

### 8.1 Characteristics

#### 8.1.1 Dimensions

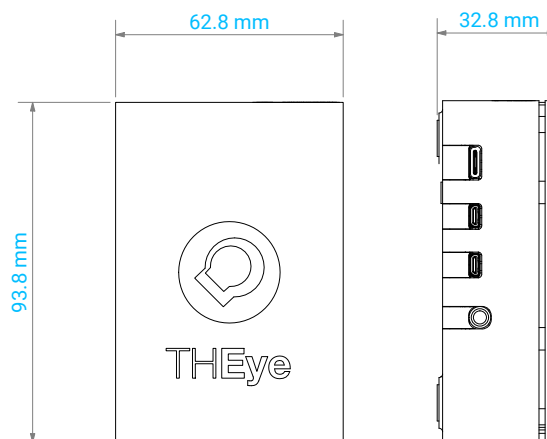

### 8.2 Installation

1. Position the THEye Gateway close to all THEye devices (10 to 20 meters).
2. Connect the USB-C power cable or a PoE power supply directly to the RJ45 port. Two short beeps sound on start-up.
3. THEye Gateway requires a wired or Wi-Fi Internet connection. For Wi-Fi network configuration, refer to the "Configuration" chapter below.
4. Configure synchronization and alarm settings as described in the "Configuration" section below.

## 8.3 How it works

THEye Gateway operation can be divided into two parts:

- The list of THEye to be synchronized and the synchronization frequency can be configured (see "Configuration" below).
- Similar to the previous section, the THEye Gateway scans nearby THEye devices and triggers an audible alarm if one of them has triggered an alarm.

Alarm ranges are individually configured for each THEye using the "THEye Controller" smartphone app (iOS & Android). When an alarm is detected, the THEye Gateway sounds at regular intervals until the alarm is cancelled using the app. (see section 5.3.3)

An email is also sent to the user's THEye.ch account address when the THEye Gateway detects an alarm. A reminder email is then sent every 24 hours until the alarm is cleared.

The verification frequency can be configured and is independent of the data synchronization frequency. Finally, the duration of the audible alarm can also be selected (see "Configuration" below).

When there are no obstacles (walls, furniture, plants, etc.), the detection range extends to a maximum of 20 meters. It's best to place the THEye Gateway in the center of all THEye to be detected.

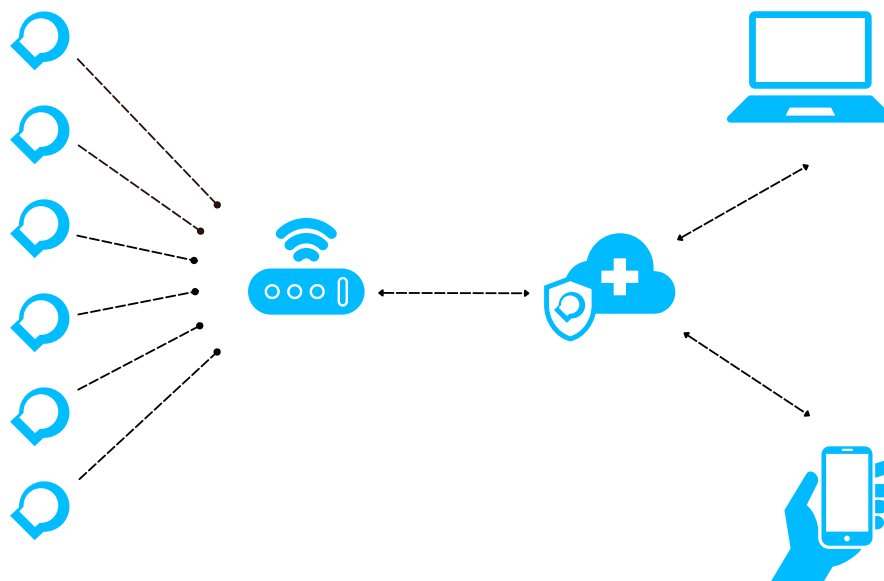

### 8.3.1 Start-up

Once started, the THEye Gateway emits 2 beeps to indicate that it is operational.

## 8.4 Configuration

As with THEye, the THEye Controller app can also be used to configure THEye Gateways. It is divided into three groups of pages:

- The Home page allows you to search for nearby THEye Gateways and initiate a connection with a THEye Gateway.
- The Device page allows you to view the status of the THEye Gateway, such as the dates of the latest and previous synchronizations.
- The Settings pages allow you to configure the THEye Gateway, i.e., network settings, synchronization periods, etc.

### 8.4.1 Home page

The home page allows you to start searching for nearby THEye and THEye Gateway devices and initiate a connection with one of them.

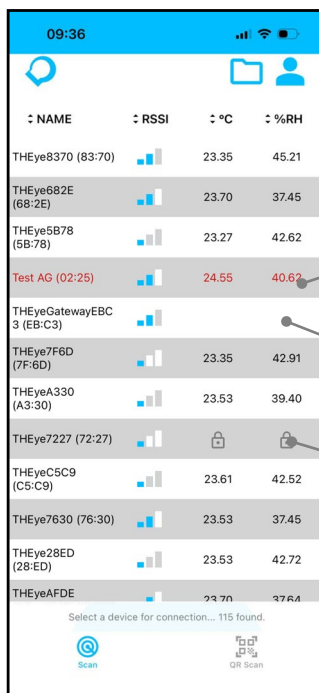

Detection of a THEye TH-2 with an activated alarm

Detection of a THEye Gateway

Detection of a THEye TH-2 in protected access

It is also possible to connect to a THEye Gateway using its QR code.

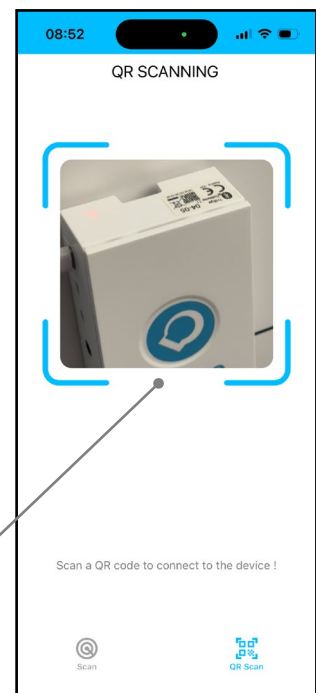

## 8.4.2 Device page

The device page allows you to view the current status of the THEye Gateway at a glance.

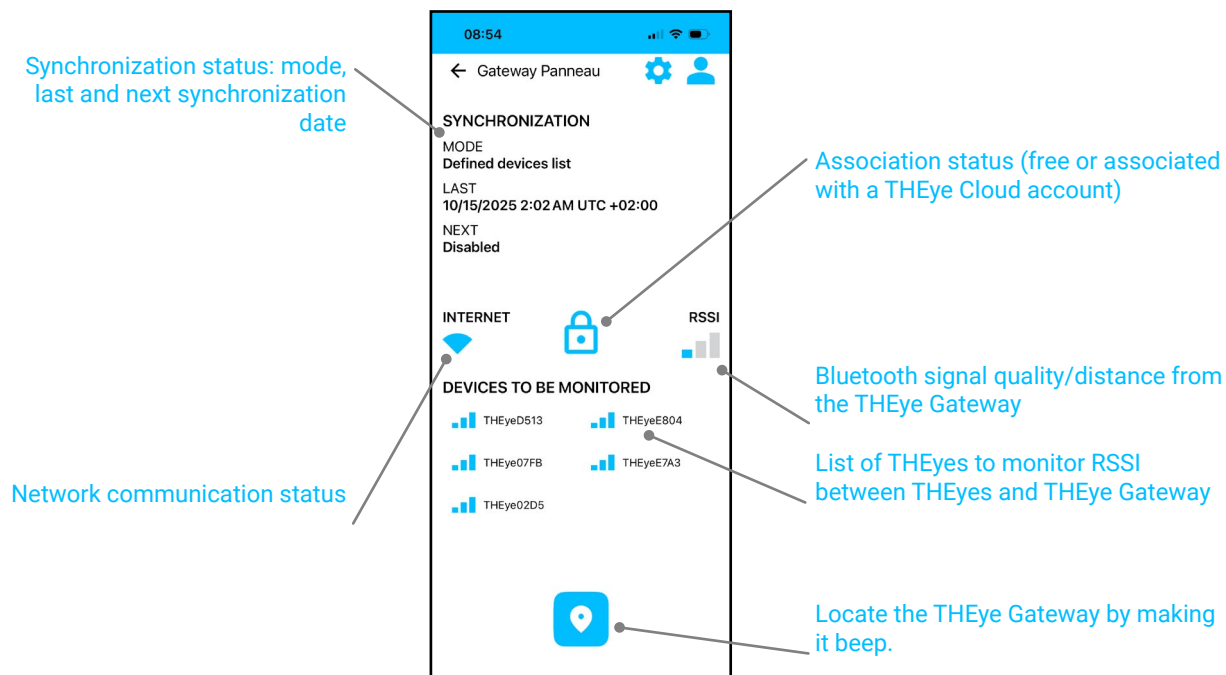

There are two synchronization modes:

- List of defined devices: THEye Gateway only synchronizes devices selected from a defined list (see section 8.4.3).
- All devices within range: THEye Gateway automatically synchronizes all devices detected in the area.



*The THEye Controller app only allows you to connect to one THEye Gateway at a time.*



*The first name displayed on a device is cached by iOS, and there is currently no way to force it to update.*

## 8.4.3 Settings pages

### Mode settings

The "Mode" settings page allows you to define synchronization rules.

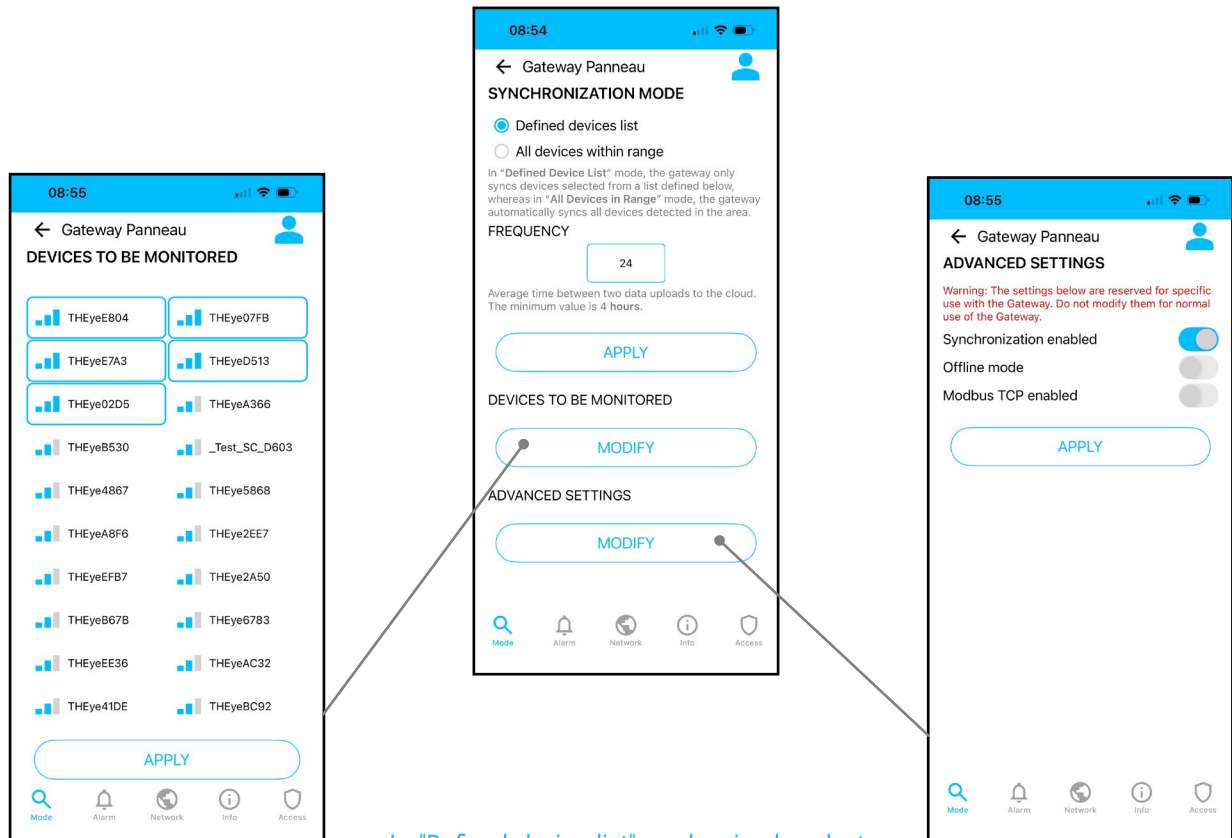

In "Defined device list" mode, simply select the devices to be synchronized from the list of detected THEyes.



For "Advanced Settings", there are three options available:

- Synchronization enabled: Normal use of information transfer with THEye Cloud.
- Offline mode: This disables all features that require internet communication.
- Modbus TCP: This allows direct communication with the THEye Gateway to retrieve sensor values. Please refer to section 8.6 for details on how to use this feature.

## Alarm settings

The “Alarm” settings page allows you to define the type of action to be taken when a THEye alarm is triggered (limit exceeded).

The THEye Gateway regularly scans the environment to detect whether a THEye is in alert mode.

If the alarm is activated and a THEye is in alert mode, the THEye Gateway transmits the information to the THEye Cloud. If the user has requested it (in their profile settings), they will receive an email notification.

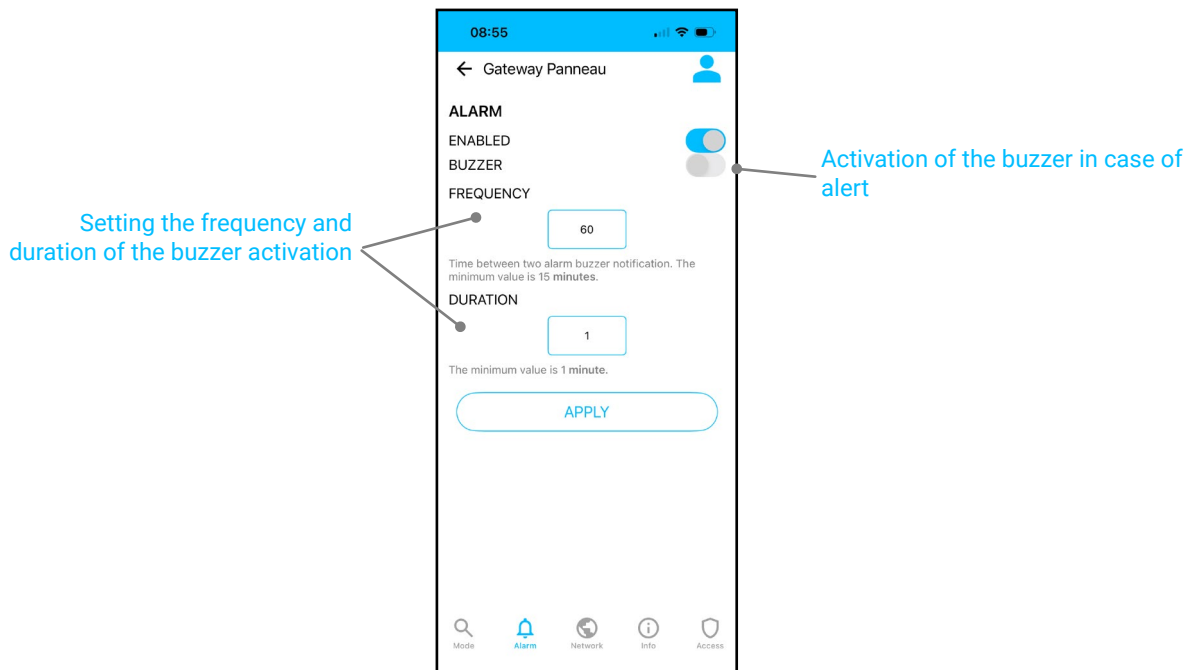

## Network settings

The “Network” settings page allows you to configure and test network settings for connecting to THEye Cloud.

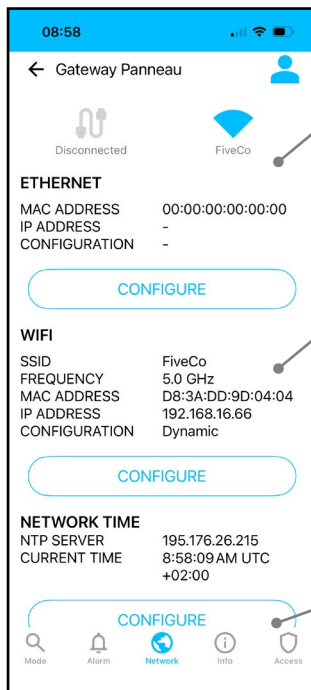

Wired network configuration

Wireless network configuration

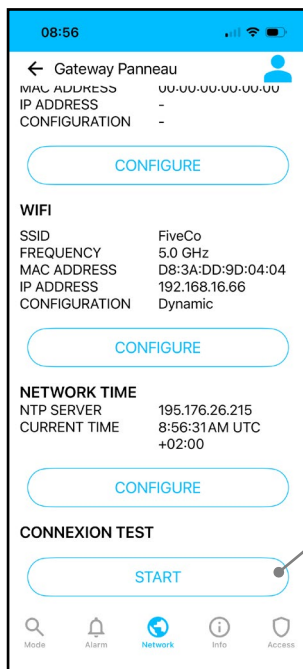
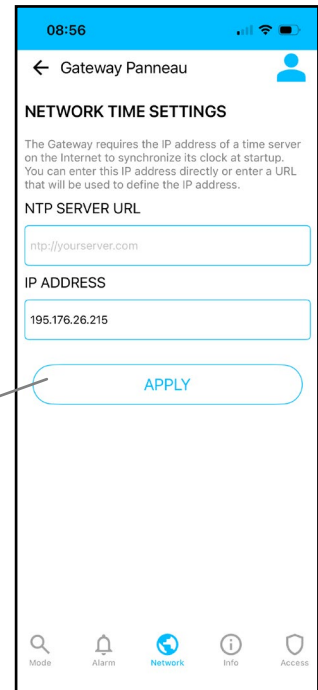

It is possible to test communication with THEye Cloud.

## Info settings

The “Information” settings page contains the identification details for the THEye Gateway

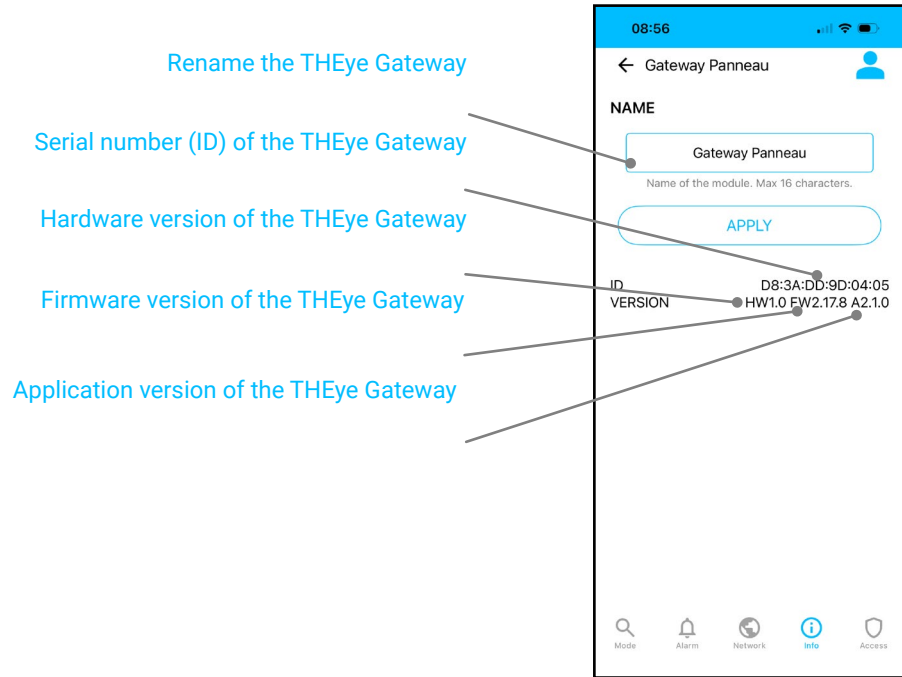

## Access settings

The “Access” settings page allows you to link the THEye Gateway to a THEye Cloud account. In addition, for a THEye Gateway linked to a THEye Cloud account, it allows you to customize access to the THEye Gateway for other users according to several configurations.

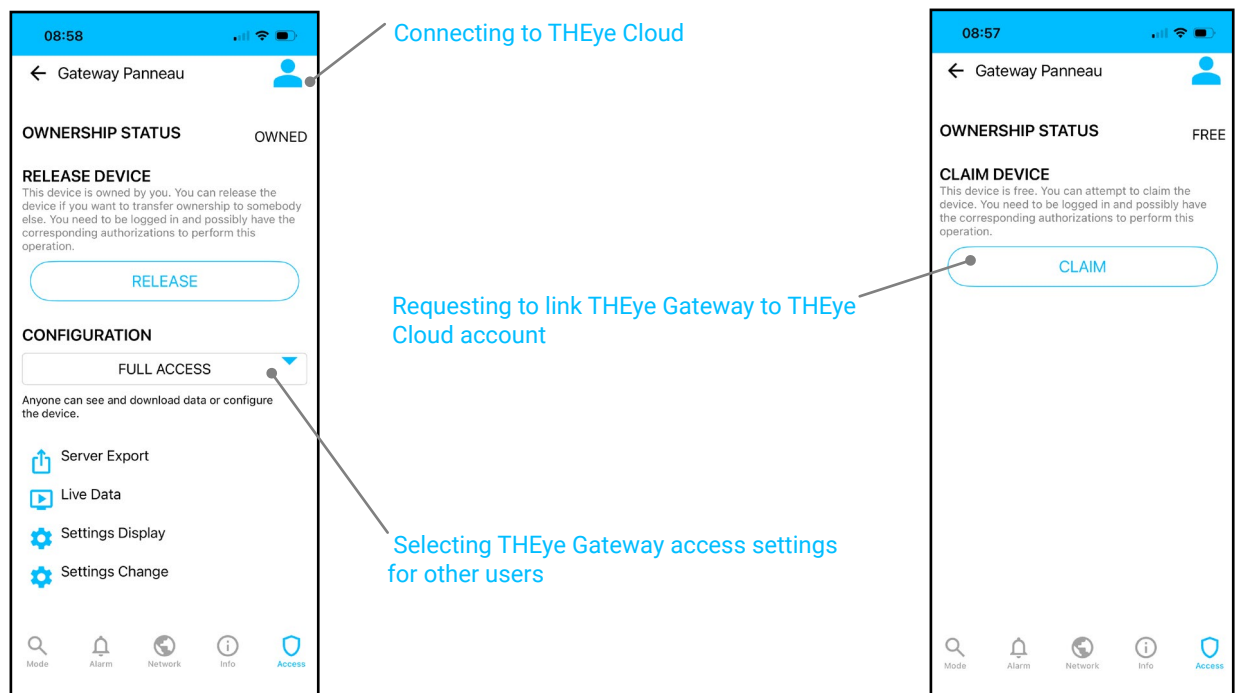

THEye Gateway access settings for other users are:

- **FULL ACCESS:** Everyone can view and download data or configure the device.
- **LIMITED ACCESS:** Users can view and download data, but device configuration is locked.
- **LIVE ONLY:** Users can only view live data. Access to historical data and device configuration is locked.
- **PROTECTED:** Other people can only upload data to the server, without viewing it.

## 8.5 Firmware update

To improve performance and fix any issues, the THEye Gateway can be automatically updated remotely (requires an internet connection). This is managed by the THEye Cloud.

The update process does not require any physical intervention and retains all user settings.

## 8.6 Modbus TCP

The Modbus protocol is a master-slave protocol. This means that a master platform must regularly query the THEye Gateway(s) on the network, which are configured as slaves.

The following information is transmitted for each THEye TH-2 sensor:

Data	Description	Units
<b>ID</b>	Unique identifier for each sensor	-
<b>Timestamp</b>	Date/time of the last measurement received by the THEye Gateway	seconds
<b>Temperature</b>	Last measured temperature	°C
<b>Humidity</b>	Last measured relative humidity	%RH
<b>RSSI</b>	Bluetooth signal strength between the THEye Gateway and the sensor	dBm
<b>Status</b>	Alarm status	See Table 2

Table 1: Data transmitted for each THEye TH-2

It is possible to set minimum and maximum temperature and humidity thresholds for each sensor using the THEye Controller application. When measurements fall outside this range, an alarm is triggered internally. For this reason, the alarm status of each sensor is included in the transmitted data:

Data	Description
<b>Current temperature alarm</b>	The current temperature exceeds the threshold
<b>Past temperature alarm</b>	The temperature has exceeded the threshold in the past

<b>Past temperature alarm (can be cleared)</b>	The temperature has exceeded the threshold in the past (can be cleared by the user)
<b>Current humidity alarm</b>	The current humidity exceeds the threshold
<b>Past humidity alarm</b>	The humidity has exceeded the threshold in the past
<b>Past humidity alarm (can be cleared)</b>	The humidity has exceeded the threshold in the past (can be cleared by the user)
<b>Hidden alarms</b>	The alarm status is hidden. The above statuses are therefore not valid

Table 2: Description of THEye TH-2 sensor status

Some alarms can be cleared (acknowledged) by the user using the THEye Controller application. This ensures that someone has taken note of the alarm in question.

## 8.6.1 Reading delay

The timestamp assigned to each measurement corresponds to the moment when the THEye Gateway received the Bluetooth signal from a sensor. It therefore does not correspond to the exact moment when the measurement was taken.

The Bluetooth transmission frequency limits the updating of measurements to a minimum of 5 seconds. Sometimes, certain Bluetooth transmissions do not reach the THEye Gateway. This can result in a delay of several tens of seconds before a new measurement is received.

## 8.6.2 Modbus TCP registers

This technical chapter presents the Modbus registers accessible in the THEye Gateway. All data is encoded in big-endian. The unit ID is set to 1 by default.

Address	Description	Units
30001	Number of devices	Type: short. (maximum: 6,553)
30001	ID [0 :15]	THEye ID on 6 bytes.
30001	ID [16:31]	
30001	ID [32:47]	
30001	Timestamp [0 :15]	UNIX epoch (UTC) in seconds
30001	Timestamp [16:31]	
30001	Temperature [0:15]	Units: °C * 100
30001	Temperature [16:31]	Conversion: Temperature [°C] = Reg. / 100

<b>30001</b>	Humidity [0:15]	Units: %RH * 100
<b>30001</b>	Humidity [16:31]	Conversion: Humidity [%RH] = Reg. / 100
<b>30001</b>	Informations	See Table 4 below
...		

Table 3: Description of Modbus registers

The order of THEyes in the registers only changes when the synchronization mode is modified. They are sorted in order of detection.

A maximum of 6,553 blocks of 10 registers, corresponding to the data from a THEye TH-2, can be read from this table.

## Information structure

The information for each THEye TH-2 sensor includes the RSSI of the last Bluetooth transmission received, as well as the status of the sensor alarms. These are organized as follows:

Bit	Description	Units
<b>0-7</b>	RSSI	Bluetooth signal strength between the THEye Gateway and the sensor, in dBm (signed byte).
<b>8</b>	Current temperature alarm	1 if the current temperature exceeds the threshold, otherwise 0.
<b>9</b>	Past temperature alarm	1 if the temperature has exceeded the threshold in the past, otherwise 0.
<b>10</b>	Past temperature alarm (can be cleared)	1 if the temperature has exceeded the threshold in the past (can be cleared by the user), otherwise 0.
<b>11</b>	Current humidity alarm	1 if the current humidity exceeds the threshold, otherwise 0.
<b>12</b>	Past humidity alarm	1 if humidity has exceeded the threshold in the past, otherwise 0.
<b>13</b>	Past humidity alarm (can be cleared)	1 if humidity has exceeded the threshold in the past (can be cleared by the user), otherwise 0.
<b>14</b>	Hidden alarms	1 if the alarm status is hidden: the above states are therefore not valid. Otherwise 0.
<b>15</b>	Reserved	Reserved

Table 4: Information structure (16 bytes)

When a THEye TH-2 sensor is not within range, its RSSI is set to -128 dBm (0x80).

## 9. Standards and safety

To ensure proper use of our technology, it is essential to observe the safety instructions given in this chapter. These recommendations are intended to prevent accidents, protect users and ensure the durability of the device. Please read them carefully and apply them systematically.

### 9.1 Safety

#### 9.1.1 Children

THEye products must be kept out of the reach of children. Small items may constitute a choking hazard if swallowed. Please keep the product in a safe place when not in use.



*Keep out of reach of children*

#### 9.1.2 Recycling

When disposing of the product, it is important to follow proper recycling practices. THEye products should either be returned to the supplier, or recycled in their entirety (without disassembly). They can be recycled together with household batteries or with smartphone or laptop-type accumulators and batteries. Collection points and recycling procedures vary according to the directives in force in the country concerned.

### 9.2 Materials and conception

THEye technology has been developed to guarantee waterproofness, vibration resistance, food compatibility and data integrity. As a result, the product cannot be disassembled, in compliance with the requirements of directives 2012/19/EU #21 and 2006/66/CE art. 11.

To minimize its ecological impact, it has been designed with reduced volume and weight, thus contributing to a smaller environmental footprint.

#### 9.2.1 Batteries

THEye products incorporate a 3V CR2450 button cell with a capacity of approx. 500 mAh. Typical life is around 5 years, but can vary from 2 to 10 years depending on the configuration mode chosen.

#### 9.2.2 Plastic and resin

THEye products are manufactured from carefully selected materials to guarantee robustness, durability and compliance with the requirements of various applications.

- THEye shell: Made from PBT (Polybutylene Terephthalate) plastic, specifically Celanex 2401/MT Natural grade.
- Resin molded into the shell: The product is made from a two-component Epoxy resin that complies with European food standards (EU) 10/2011 and 2020/1245.

### 9.3 IP68

THEye TH-2 and THEye TH-2 ISO products comply with IP68 protection rating.

Id	Description
6	Totally protected against dust
8	Submersible equipment beyond 1 m

### 9.4 Storage

The THEye TH-2 has to be stored between -40 and +70°C.

The battery self-discharge is:

- <1%/year @≤23°C
- =7%/year @70°C

### 9.5 Working pressure

Experimental laboratory tests:

- Working pressure : -400 to +5500m (from sea)
- Working absolute pressure: 0.05MPa to 2MPa (20 Bar)

Typical RH error, with absolute air pressure:

- 0.05MPa to 0.3MPa (3 bars): -0.35% /MPa (-0.035% /bar)
- 0.3MPa to 2 MPa (20 bars): -0.49% /MPa (-0.049% /bar)

## 9.6 EC Declaration of conformity

### EC Declaration of Conformity



Document revision: 2.1 , 2025-02-25  
 Hereby we: FiveCo  
 Address: En Budron H 11,  
 1052 Le Mont-sur-Lausanne, Switzerland  
 Product description: Bluetooth data logger  
 Type designation(s): THEye TH2  
 Trademark: FiveCo, THEye



The previous equipment is declared to be in conformity with the following directives and international standards.

From <b>Directive 2014/53/EU + (EU)2022/2380</b> Harmonised standards: ETSI EN 300 328 V2.2.2 ETSI EN 301 489-17 V3.2.4 (2014/53/EU)	Radio equipment device (RED):  RED - 2.4GHz band data transmission RED - Broadband data transmission
From <b>Directive 2014/30/EU</b> Harmonised standards: residential industrial environment EN 61000-6-1:2019 EN 61000-6-2:2019 IEC 61000-6-1:2016 IEC 61000-6-2:2016 EN IEC 61326-1:2021 EN 61000-6-3:2021 EN 61000-6-4:2019 IEC 61000-6-3:2020 IEC 61000-6-4:2018 EN IEC 61326-1:2021	Electromagnetic compatibility directive (EMC):  EMC – Immunity  EMC - Emission
EN IEC 62479 :2010	Human exposure to low power electronic EMF
EN IEC 62368-1:2020	Safety
<b>Directive (EU)2017/2102 + (EU)2015/863</b> (EC)1907/2006 REACH + SVHC 241 - CR2450N battery contains 1,2 dimethoxyethane, and must be correctly recycled (EU)2023/1542 (EU)2019/1020 #39 (EC)2006/66 article 18 + (EU)2018/849 (EU)2019/1021 UN38.3 IP68 (24 hours under 1.5 meter)	RoHS 3 Prohibited substances list Battery waste Battery sealed EU Battery POP Lithium transport Water + dust protection

Frequency band: Bluetooth LE 2402MHz to 2480MHz ISM Band  
 Maximum RF output power: < 4dBm (Bluetooth)

The technical files are maintained at the company address listed above.

Persons responsible for making this declaration

Name Greppin Xavier  
 Position/Title CTO - FiveCo  
 Place of issue Le Mont-sur Lausanne, Switzerland



## 9.7 EN12830

The THEye TH-2 ISO product complies with the EN12830 standard for transport, storage and distribution of temperature sensitive goods.

The ISO/IEC 17025:2017 certificate is provided upon request.

Contact address  
FiveCo – Innovative Engineering  
En Budron H11  
1052 Le Mont-sur-Lausanne  
Suisse  
Tel : + 41 21 632 60 10  
Email: [info@theye.ch](mailto:info@theye.ch)  
Web: [theye.ch](http://theye.ch)

<b>Review</b>	<b>Date</b>	<b>Authir</b>	<b>Note</b>
0.1	08.03.22	NS	Initial version
0.11	13.12.22	PHD	Release version
0.12	05.05.24	MB	Release version
0.13	09.12.24	MB	Release version, multilingual
0.14	20.12.24	MB	Chapter 9.1 Standards and safety chapter added
0.15	22.01.25	MB	Pictures of the smartphone app
0.16	16.07.25	MB	Chapters 9.4 & 9.5 added, Iconography updated
0.17	23.10.25	MB	Updated chapter 8 of the Gateway